

A Compact Design of Slots Loaded Microstrip Patch Antenna for dual band operation

Niraj Narayan, Avinash Rai

Department of Electronics and Communication Uit rgpv Bhopal, India

Abstract: In this paper, a compact design of microstrip patch antenna for defense and satellite communication is designed and results are analyzed through HFSS. Three slots are loaded on the top of the patch to enhance the bandwidth of reference rectangular microstrip patch antenna. The simulated antenna return loss is -18.5dB at 6.75 GHz, -18.2dB at 11.8 GHz and found bandwidth of 82.2% and 38.03% at 6.75 GHz, 11.8 GHz respectively.

Keywords—Microstrip patch antenna, Dual band, Slotted, High Bandwidth, Wireless, HFSS.

I. INTRODUCTION

Microstrip patch antennas are transmitting and receiving antennas with numerous applications in different fields such as satellite communication, radar, remote sensing, GPS receivers and other mass-produced wireless products. Microstrip patch antennas are popular due to their attractive features, such as compactness, low profile planar structure, light weight, and compatibility with integrated circuits [1-4]. In spite of, narrow bandwidth is a considerable problem of microstrip patch antennas that restricts its applications. There are various bandwidth enhancement techniques but the simplest one is the loading of different shape and size of slots and notches on the patch or in the ground plane [5]. A number of researchers have reported microstrip patch antennas with enhanced bandwidth such as compact broadband slotted rectangular microstrip antenna with bandwidth of 26.7% [4], M-slot folded patch antenna reported bandwidth of 21.17% [6], and W-shaped microstrip patch antenna reported 36.75% bandwidth [7].

In this paper, slots loaded dual-band microstrip patch antenna has been designed and analyzed to obtaining improved bandwidth for wireless applications. By selecting proper dimensions and positions of the slots, 3dB bandwidth improved up to more than 80% of the resonant frequency. The proposed antenna is optimized using HFSS simulation software and results are discussed in terms of antenna parameters.

II. ANTENNA DESCRIPTION

Designed antenna structure shown in figure .1 consist radiating patch of copper on porcelain dielectric substrate of relative permittivity 5.7 and having thickness of 1.6 mm. Multiband behavior of patch antenna is obtained by providing three slots of dimensions $L_1 \times W_1$, $L_2 \times W_2$ and $L_3 \times W_3$ near the radiating edges of patch [1-4]. Table. I mentioned shows the dimensions of proposed antenna.

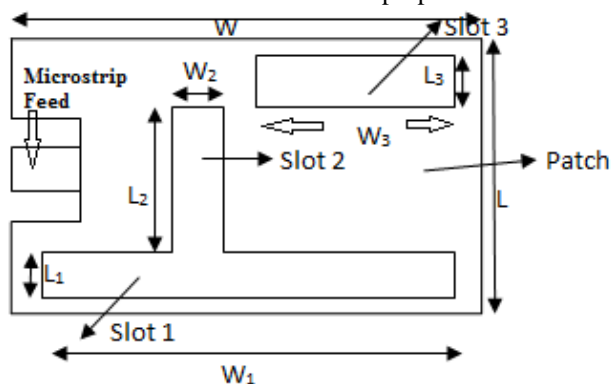

Figure 1. Geometry of proposed antenna

The parameters of the patch are calculated by the following equations [1-3].

Width:

$$W = \frac{u}{2 f_r} \sqrt{\frac{2}{\epsilon_r + 1}} \quad (1)$$

where

u = free space velocity

f_r = resonant frequency

ϵ_r = relative permittivity
 Effective dielectric constant:

For $\frac{w}{h} > 1$

$$\epsilon_{reff} = \frac{\epsilon_r + 1}{2} + \frac{\epsilon_r - 1}{2} \left[1 + 12 \frac{h}{w} \right]^{-\frac{1}{2}} \quad (2)$$

Length:

$$L = \frac{u}{2f_r \sqrt{\epsilon_{reff}}} \quad (3)$$

TABLE. I ANTENNA DIMENSIONS

Parameter	Value
Length of patch (L)	25mm
Width of patch(W)	38mm
Substrate thickness(h)	1.6mm
Dielectric constant of substrate (ϵ_r)	5.7
Slot 1 ($L_1 \times W_1$)	5mm x 36mm
Slot 2 ($L_2 \times W_2$)	5mm x 16 mm
Slot 3 ($L_3 \times W_3$)	5mm x 18 mm

III. RESULTS AND DISCUSSIONS

The proposed patch antenna is simulated using ansoft HFSS v.13 and simulated results of return are shown in figure 2. The return loss of -18.5 dB is obtained at 6.75 GHz with 10 dB bandwidth of 82.2%. The return loss at second resonant frequency 11.8 GHz is -18.2 dB with 10 dB bandwidth of 38.03%.

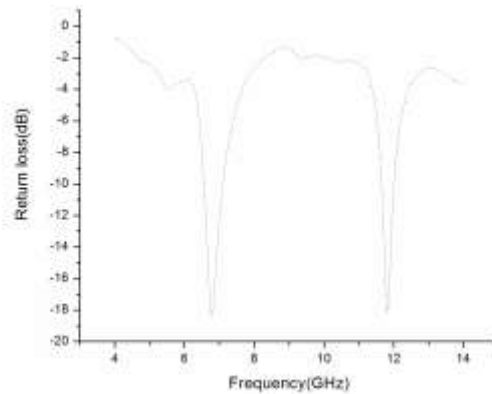

Figure 2. Return loss vs. Frequency of Proposed antenna

Simulated value of voltage standing wave ratio (VSWR) shown in figure 3 are observed as 1.17 and 1.2 which are close to 1.

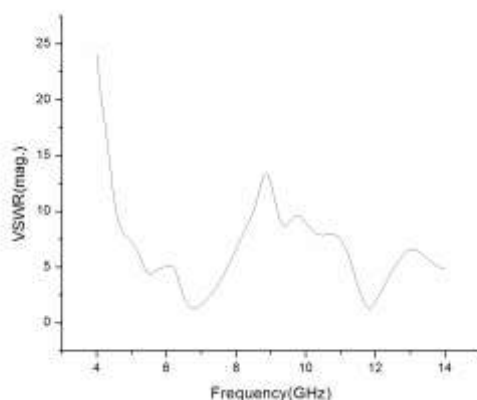

Figure 4. VSWR vs. Frequency of Proposed Antenna

IV. CONCLUSIONS

A dual band microstrip patch antenna with slots loaded on radiating patch is proposed and simulated for wireless applications at 6.75 GHz and 11.8 GHz. With the introduction of the slots the bandwidth has been achieved up to 82.2% of resonant frequency. This antenna is very simple and convenient for design.

REFERENCES

- [1] Garg,R.,Bhartia,P.,Bahl I.andIttipiboon A. "Microstrip Antenna Design Hnadbook" Artech House Norwood 2001.
- [2] Lee, Y.C., Sun, J.S., "A new printed antenna for multiband wireless applications," *IEEE Antennas Wireless Propaation Letters*, **8**, 402–404(2009).
- [3] P.Subbulakshmi,R.Rajkumar, "Design and characterization of corporate feed Rectangular Microstrip Patch Array Antenna," *IEEE International conference on Emerging trends in Computing and Nanotechnology (ICECCN-2013)*.
- [4] A.A Deshmukh and K.P. Ray, "Compact broadband slotted rectangular microstrip antenna," *IEEE Antennas and Wireless Propagation Letters*, vol. 8, pp. 1410-1413, 2009.
- [5] Arnab Das, Bipra Datta, Samiran Chatterjee, Noumita Mukherjee, Santosh Kumar Chowdhury, "Multi-resonant Slotted Microstrip Antenna for C, X and Ku-Band applications," *IOSR Journal of Electrical and Electronics Engineering*, ISSN :(2278-1678) Volume 2, Issue 6 (Sep.-Oct. 2012), PP 47-52.
- [6] F. Jolani, A. M. Dadgarpour, H. R. Hassani, "Compact M-slot folded patch antenna for WLA," *Progress in Electromagnetics Research*, vol. 3, pp. 35-42, 2008.
- [7] A. A. Lotfi Neyestanak, F. Hojjat Kashani, K. Barkeshli, "W-shaped enhanced-bandwidth patch antenna for wireless communication," *Wireless Personal Communications*, vol. 43, no. 4, pp. 1257-1265, 2007.