

Performance Comparison of Multi-Carrier CDMA Using QPSK and BPSK Modulation

Karmjeet Singh¹, Er. Rajbir Kaur²

¹(Student University college of Engg, Punjabi University Patiala, India)

²(Assist. Professor University college of Engg, Punjabi University Patiala)

Abstract: MC-CDMA (Multi Carrier Code Division Multiple Access) plays an important role in modern wireless communications. Modern communication required an efficient spectrum usage and capacity and throughput. MC-CDMA provided the solution of these problems. MIMO refers to links with multiple antennas at the transmitter and receiver side. CDMA systems combined with multiple antennas is a promising technique, beyond 3G and 4G wireless communications. MIMO provides spatial diversity, which mitigates the fading. The usage of multiple antennas can significantly improve the performance of wireless communication system. This work also derives simulation through MATLAB of average bit error rate verses bit energy to noise ratio of multicarrier code division multiple access over Rayleigh channel using QPSK and BPSK modulation additive white Gaussian noise.

Keywords: AWGN, BER, MC-CDMA, QPSK Modulation, Rayleigh Channel.

I. INTRODUCTION

Wireless communications is an emerging field, which has seen enormous growth in the last several years. The growth of video, voice and data communication over the Internet, and the equally rapid pervasion of mobile telephony, justifies expectations for mobile multimedia. Due to this growth of multimedia communication, the users demanded high data rate communication systems in wireless environment where the spectral resource is scarce. To fulfill the requirements new technologies like Code Division Multiple Access and Orthogonal Frequency Division Multiplexing (OFDM) are few promising systems for the 4G communication standards. Unique codes are used distinguish different users using same frequency band is the basic idea behind CDMA. This led to an achievement of soft capacity with limitation self-interference and Multiple User Interference (MUI). Thus the channel characteristics and spreading code characteristics which are responsible for the above interference should be taken care to increase the capacity[1].

II. MULTI-CARRIER CDMA OVERVIEW

2.1. Multi-carrier CDMA (MC-CDMA)

Two main variations of the MC spread spectrum systems are the MC-CDMA (frequency domain spreading) and MC direct sequence CDMA (MC-DS-CDMA) (time domain spreading). One way of looking at MC-CDMA is as a combination of CDMA and OFDM, resulting in better frequency diversity and higher data rates. In MC-CDMA, each symbol is spread using code chips and transmitted on several subcarriers. There is no necessity for the number of carriers to be equal to the code length; thus offering a degree of flexibility in our design. MC-DS-CDMA differs in the fact that the data is spread in time domain rather than in frequency; with each sub channel representing a regular DS-CDMA system. The principle of MCCDMA is that a single data symbol is transmitted over independent subcarriers. The eminent advantage of MC-CDMA is the increase in bandwidth efficiency; the reason being the multiple access made possible through proper systems design using orthogonal codes [2-3].

2.2. Need for MCCDMA

MC-CDMA takes advantage of both OFDM and CDMA and makes an effective efficient transmission system by spreading the input data symbols with spreading codes in frequency domain. It uses a number of narrowband orthogonal subcarriers with symbol duration longer than the delay spread. This makes it unlikely for all the subcarriers to be affected by the same deep fades of the channel at the same time thereby performance increases. During transmission becomes easier with longer symbol durations. As the number of paths increases the performance of the two systems improves at first due to diversity, then, it starts to deteriorate due to the increased interference from large number of paths of all users. In general, there is an optimum number of paths that depends on the system used and the number of users. As the number of users increases, interference from all users through all paths increases. Therefore, the optimum number of paths decreases [4].

III. Mc-Cdma Block Diagram

In this section we describe the transmitter and receiver model of MC-CDMSA system. Here symbols are modulated on many subcarriers to introduce frequency diversity instead of using only one carrier like CDMA. Thus MC-CDMA is robust against deep frequency selective fading compared to DS-CDMA[2]. Each user data is first spread using a given high rate spreading code in frequency domain. A fraction of the symbol corresponding to a chip of the spreading code is transmitted through different subcarriers[5].

3.1. MCCDMA Transmitter Model

MC-CDMA transmitter is similar to OFDM transmitter with small difference. In OFDM many different symbols are transmitted by subcarriers but in MC-CDMA same symbol is transmitted by different subcarriers. The explanation of the above concept is clearly shown in figure1. The input data rate symbols are converted to parallel streams. Then each parallel stream is spread using spreading codes like Walsh, Hadamard etc.

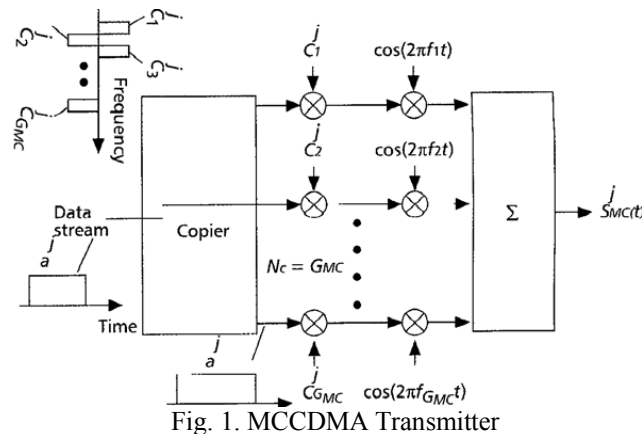

Fig. 1. MCCDMA Transmitter

The OFDM system associated with the CDMA system converts the symbols to time domain samples by Inverse Fast Fourier Transform (IFFT) and assigns a subcarrier for each symbol. Then the subcarriers are multiplexed to form as a serial stream. Before the transmission the serial stream is converted to blocks and each block is separated by a guard frame. The guard frame is usually a zero symbols or known symbols. In OFDM the guard symbols are cyclic prefix of the block where a part of the symbols belonging to a block is appended which has various advantages.

In this figure, the main difference between MCCDMA & OFDM is that the MC-CDMA scheme transmits the same symbol in parallel through several subcarriers whereas the OFDM scheme transmits different code of the user in the frequency domain. The input data stream is multiplied by the spreading code. The users are separated by different codes. All data corresponding to the total number of sub carriers are modulated in baseband by an inverse fast Fourier transform (IFFT) and converted back into serial data. Then, a cyclic prefix is inserted between the symbols which is a repeat of the end of the symbols at beginning, to combat the inter-symbol interference (ISI) and the inter-carrier interference (ICI) caused by multipath fading. And hence the cyclic prefix length is chosen such that it is greater than the delay spread of the channel. In MC-CDMA transmission, it is essential to have frequency non selective fading over each sub carrier. Therefore, if the original symbol rate is high enough to become subject to frequency selective fading [6], the input data have to be serial to parallel (SIP) converted into parallel data sequences and each SIP output is multiplied with the spreading code of length GMC. In order to improve the performance of the system, an appropriate approach for channel estimation is, to use dedicated pilot symbols that are periodically inserted in the transmission frame (in the time domain), also known as block-type pilot channel estimation. The pilot tones can also be inserted into each symbol (in the frequency domain) with a given frequency spacing; this is known as comb-type pilot channel estimation[6-7].

3.2. MCCDMA Receiver model

The MCCDMA receiver configuration for the j^{th} user is shown in Figure 2. The received signal is first down converted.

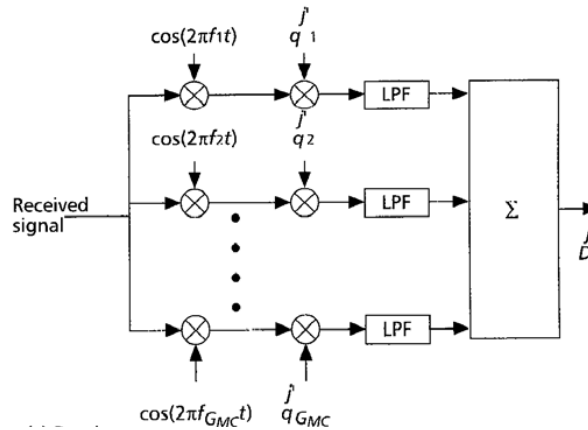

Fig. 2. MCCDMA Receiver

Then, the cyclic prefix is removed and the remaining samples are serial to parallel converted to obtain the m -subcarriers components (corresponding to the a_j data), where $m = 1, 2, \dots, GMC$. The m -subcarriers are first demodulated by a fast Fourier transform and then multiplied by the gain q_i to combine the received signal energy scattered in the frequency domain.

IV. Mimo Overview

MIMO systems use multiple antennas at both transmitter and receiver, so both transmit and receive diversity are applied to mitigate fading resulting from signal fluctuations through the wireless channel. Based on the degree at which the multiple data replicas are faded independently, the system provides diversity gains representing the difference in SNR at the output of the diversity combiner compared to that of single branch diversity at certain probability level. A MIMO system consisting of N transmit antenna elements equal to eight, and of M receive antenna elements equal to two was modeled, accordingly diversity order of 16 can be achieved. Combining the multiple versions of the signals created by different diversity schemes is needed for improving the performance. The paper applies maximal ratio combining (MRC) technique using maximum-likelihood (ML) decoder to combine these M received signals to resonate on the most likely transmitted signal. The sum of the received SNRs from these M different paths is the effective received SNR of the system with diversity M . The receiver needs to demodulate all M receive signals in case of MRC for a source with M independent signals in the receive antennas [8-9].

V. Simulation Of Mc-Cdma

Here we discuss BER for QPSK in a Rayleigh multipath channel. In discussion on Rayleigh channel, a circularly symmetric complex Gaussian random variable is considered which is of the form, $h = h_{re} + jh_{im}$ where, real and imaginary parts are zero mean independent and identically distributed (iid) Gaussian random variables with mean 0 and variance σ^2 . The magnitude $|h|$ which has a probability density, $p(h) = h/\sigma^2 e^{-(2h/\sigma^2)}$, $h \geq 0$ is called a Rayleigh random variable. This model, called Rayleigh fading channel model, is reasonable for an environment where there are large number of reflectors.

The received signal in Rayleigh fading channel is of the form, $y = hx + n$, where 'y' is the received symbol, 'h' is complex scaling factor corresponding to Rayleigh multipath channel, 'x' is the transmitted symbol (taking values +1's and -1's) and 'n' is the Additive White Gaussian Noise (AWGN). Assumptions:

1) The channel is flat fading - means that the multipath channel has only one tap. So, the convolution operation reduces to a simple multiplication.

2) The channel is randomly varying in time - meaning each transmitted symbol gets multiplied by a randomly varying complex number 'h'. Since 'h' is modeling a Rayleigh channel, the real and imaginary parts are Gaussian distributed having mean 0 and variance 1/2.

3) The noise 'n' has the Gaussian probability density function with

$$P(n) = (1/\sqrt{2\pi\sigma^2}) e^{-(n-\mu)^2/2\sigma^2}, \mu = 0 \text{ and } \sigma^2 = N_0/2 \quad (1)$$

4) The channel 'h' is known at the receiver. Equalization is performed at the receiver by dividing the received symbol y by the h. $\hat{y} = y/h = (hx+n)/h = x + \hat{n}$, where, $\hat{n} = n/h$ is the additive noise scaled by the channel coefficient.

5.1 Bit Error Rate

BER computation in A WGN, the probability of error for transmission of either + 1 or -1 is computed by integrating the tail of the Gaussian probability density function for a given value of bit energy to noise ratio E_b/N_o . The bit error rate is,

$$P_b = 1/2 \operatorname{erfc}(\sqrt{E_b/N_o}) \tag{2}$$

.However in the presence of channel 'h', the effective bit energy to noise ratio is $|h|(E_b/N_o)$. So the bit error probability for a given value of 'h' is,

$$P_{b/h} = 1/2 \operatorname{erfc}(\sqrt{|h|^2 E_b/N_o}) = 1/2 \operatorname{erfc}(\sqrt{\gamma}) \tag{3}$$

where $\gamma = |h|^2 (E_b/N_o)$. To find the error probability over all random values of $|h|^2$, one must evaluate the conditional probability density function $P_{b/h}$ over the probability density function of γ . [10].

5.2 Simulation model

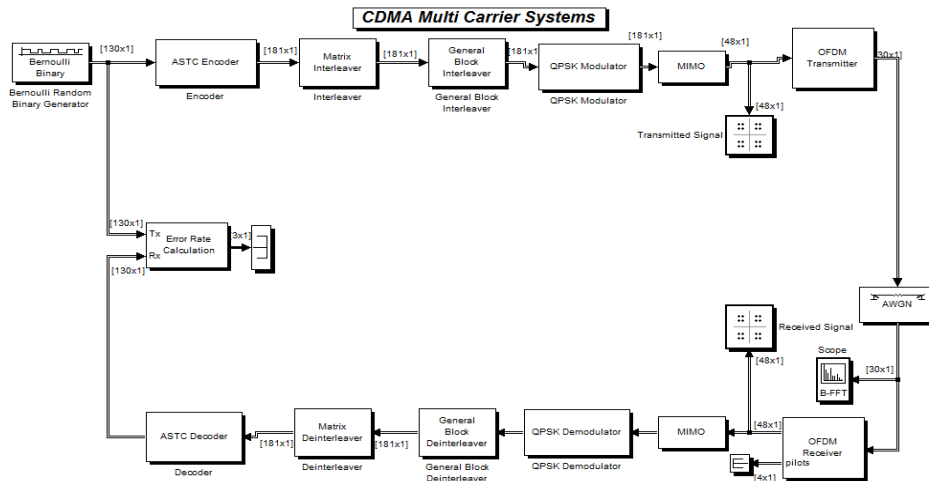

Fig. 3. simulation model of MC-CDMA

We performs the following procedure: Initially we generate random QPSK modulated and BPSK modulation symbols +1's and -1's, then we pass them through AWGN channel after that we demodulate the received symbol based on the location in the constellation, then we count the number of errors finally repeat the same for multiple E_b/N_o . Fig. 3 shows the simulation model of the MC-CDMA system. Fig. 4 shows the transmitted signal. Fig. 5 shows the power level of the transmitting signal. And Fig. 6 shows the received signal.

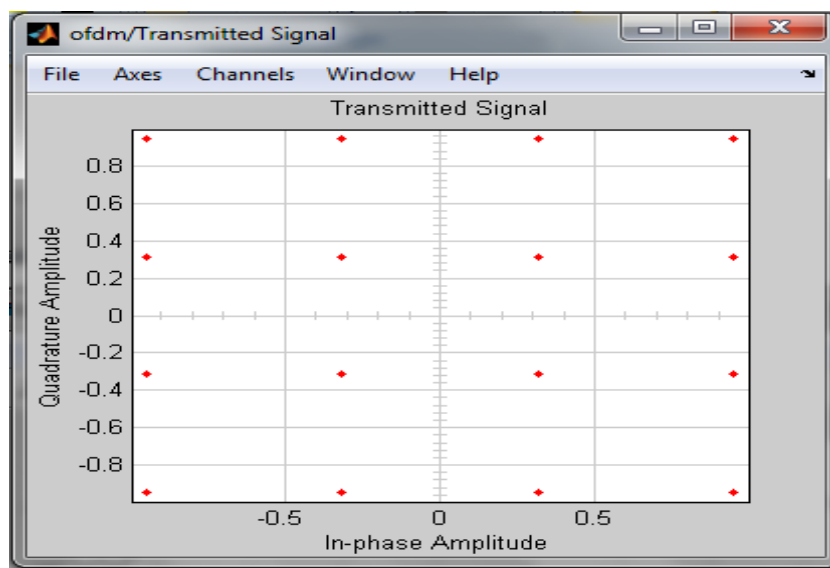

Fig. 4 Transmitted signal

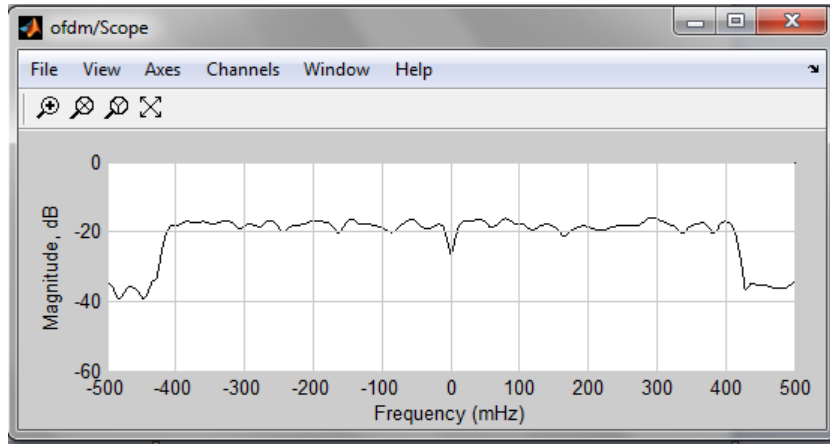

Fig. 5 shows the power level of the transmitting signal

Fig. 7 shows the simulated result in term of BER using one transmitting antenna and one receiving antenna for QPSK modulation and BPSK modulation technique. The result shows that QPSK modulation technique has better result than BPSK modulation technique. Fig. 8 BER Using two transmitting antenna and two receiving antenna for QPSK modulation technique. The result show that it has better result than one transmitting and receiving antenna due antenna diversity.

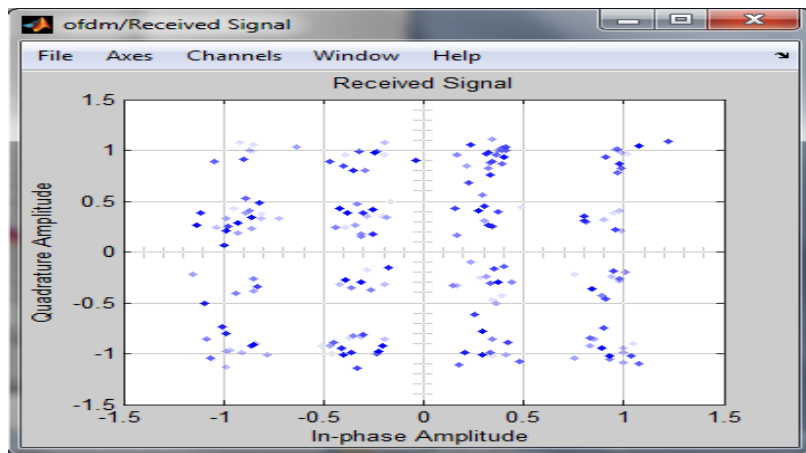

Fig. 6 shows the received signal

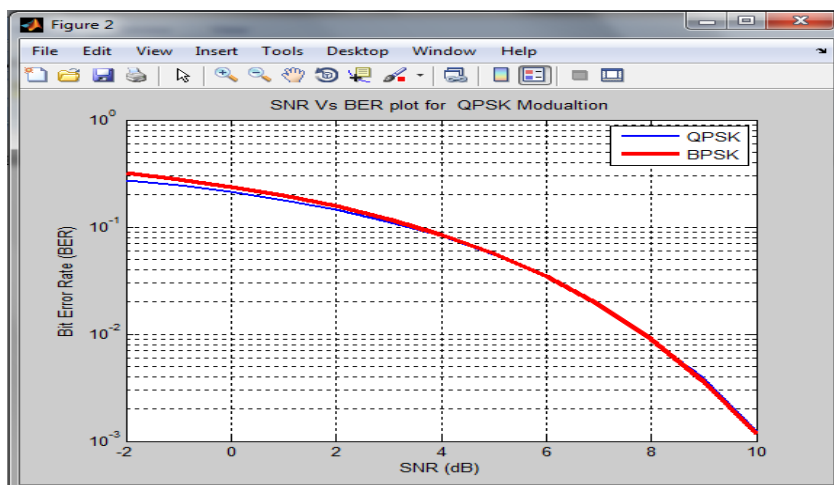

Fig. 7 BER Using one transmitting antenna and one receiving antenna for QPSK and BPSK Modulation technique.

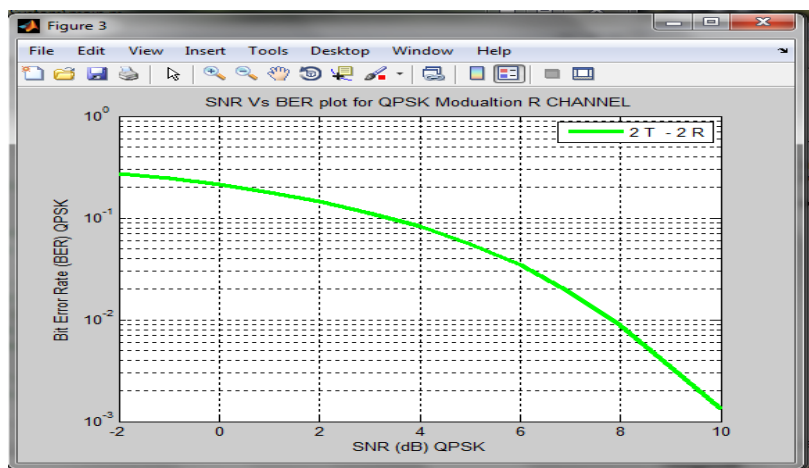

Fig 8 BER Using two transmitting antenna and two receiving antenna

VI. Conclusion

In this paper we have tried to study and implement the Multi-Carrier CDMA system using and derive the BER Vs E_b/N_0 performance for MCCDMA communication system using variable number of bits with QPSK and BPSK modulation on Rayleigh channel and Additive White Gaussian Noise. Simulation of BER Vs E_b/N_0 with QPSK modulation shows that as BER performance decreases, the bit energy to noise ratio, E_b / N_0 increases. We noted that multiple with more numbers of antennas has better performances due to the antenna diversity. Here in MIMO MCCDMA signals received will never be corrupted because copy of same signals are transmitted over all subcarriers and error or overlapping of signals will never take place because of orthogonality property

References

- [1] Hara, S., & Prasad, R. (1999). "Design & performance of MC-CDMA system in frequency-selective fading channels". *IEEE Trans. On Veh. Tech.* 48, (5) 1584-1595.
- [2] Yee, N., Linnartz, J. and Fettweis, G., "Multi-carrier CDMA for indoor wireless radio networks", *Proc. International Symposium on PIMRC-93*, 109-113, Sept 1993.
- [3] DS-SS, MC-CDMA, MT-CDMA for Mobile Multi-Media communication Vehicular Technology Conference, 1996. "Mobile Technology for the Human Race", *IEEE 46th*.
- [4] Lui, Hui (2000), "Signal processing application in CDMA communication".
- [5] Hara, Shinsuke and Prasad, Ramjee (1997), "Overview of Multicarrier CDMA", *IEEE Comm. Magazine*, 35, 126.
- [6] Hsieh, M.-H. and Wei, C.-H. (1998), "Channel estimation for OFDM systems based on comb-type pilot arrangement in frequency selective fading channels", *IEEE Transactions on Consumer Electronics*, 44, 217.
- [7] Coleri, S., Ergen, M., Puri, A., and Bahai, A. (2002), "A study of Channel estimation in OFDM systems", *In 56th IEEE Vehicular Technology*.
- [8] A. Sharmila and Srigitha S. Nath, (2012) "Performance of MIMO Multi-Carrier CDMA with BPSK Modulation in Rayleigh Channel", *ICCCE*, 12 & 13 April, 2012.
- [9] Maleki-Tehrani, A. Hassibi, Cioffi, J.M., "Adaptive Equalization of Multiple input Multiple output (MIMO) frequency selective channels", *conference on Signals, Systems, and Computers*, 1999, Vol. 1, pp. 547-551.
- [10] Pragma Pallavi, Pradipta Dutta, "Multi-Carrier CDMA Overview with BPSK Modulation In Rayleigh Channel", *IEEE*, 2010.