

## Experimental Investigation of the Performance of a Laboratory Screw Jack

Stephen Tambari<sup>1</sup>, Petaba Lemii<sup>2</sup>, Kanee Sorbari<sup>3</sup>, Nzidee lelesi<sup>4</sup>

<sup>1,2,3,4</sup>Department of Mechanical Engineering Rivers State Polytechnic, P.M.B 20, Bori.

---

**Abstract:** The purpose of this project was to carry out an experimental investigation on the performance of a laboratory screw jack in order to ascertain the force ratio (Mechanical Advantage), Velocity Ratio and Mechanical Efficiency of the machines at different loads. The experiment was done at different loads of: 450N, 400N, 350N, 300N, 250N, 200N, 150N, 100N and the Mechanical Advantage, Velocity Ratio and Mechanical Efficiency were calculated for true and approximate values and graphical relationships were established between efficiency and load, effort and load, effort against load using micro soft excel. It was established that, the machine was most efficiency of a screw jack is always less than 50% since the Mechanical Advantage and Velocity Ratio is less than half. The investigation also revealed that the efficiency not being constant was as a result of the different loading conditions the machine must overcome which include great frictional forces between the screw and the threaded base within which it forms.

**Keywords:** Laboratory, screw jack, experimental investigation, performance.

---

### I. Introduction

The main aim of engineering and technology is to make life comfortable for man. One of such comfort is by applying a small effort in order to lift a heavy load. The screw jack is one of such invention designed for lifting heavy loads. It is a portable device consisting of a screw mechanism used to raise or lower loads and its principle is similar to that of an inclined plane. The laboratory screw jack is a prototype used in the mechanics of machines laboratory for demonstrating how the real screw jack used for changing tires of vehicle and lifting of vehicles works. The laboratory screw jack comprises of the turn table for lifting loads, the pulley for supporting the cord, effort hanger, the square screw thread and the base. There are basically two main types of jacks; the hydraulic jack consists of a cylinder and a piston mechanism. The movement of the piston rod is used to raise or lower the load. The mechanism, much like a scissor, to lift up a vehicle for repair or storage. It typically works in just a vertical manner and it opens and folds closed, applying pressure to the bottom supports along the crossed pattern to move the lift.

#### 1.2 Purpose Of Study

This study is aimed at investigating the performance of a laboratory screw jack using the Mechanical Advantage, Velocity Ratio and Mechanical Efficiency of the machine obtained at different loads.

#### 1.3 Benefit Of Study

This work will be useful in the mechanics of machines laboratory of the department of mechanical engineering for practical exercise and research work.

### II. Operational Considerations

- Maintain low surface contact pressure
- Maintain low surface speed
- keep the mating surfaces well lubricated
- keep the mating surfaces clean
- keep heat away

### III. Materials And Method

#### 3.1 Experimental Methods

The apparatus was subjected to various testing condition in the laboratory using load of different magnitudes and weights were added to the effort hanger until the turntable moves at uniform speed. The magnitude of the load and effort, the pitch of the screw thread and diameter of the turntable, the length of the cord made by the effort in one revolution of the turntable were all measured and recorded. The procedure was repeated for eight (8) times for each of the following loads: 405N, 400N, 350N, 300N, 250N, 200N, 150N and

100N respectively. The Mechanical Advantage, the Velocity Ratio and Mechanical Efficiency for each load were calculated and recorded.

Figure 1.0: Experimental set up of the laboratory screw jack.

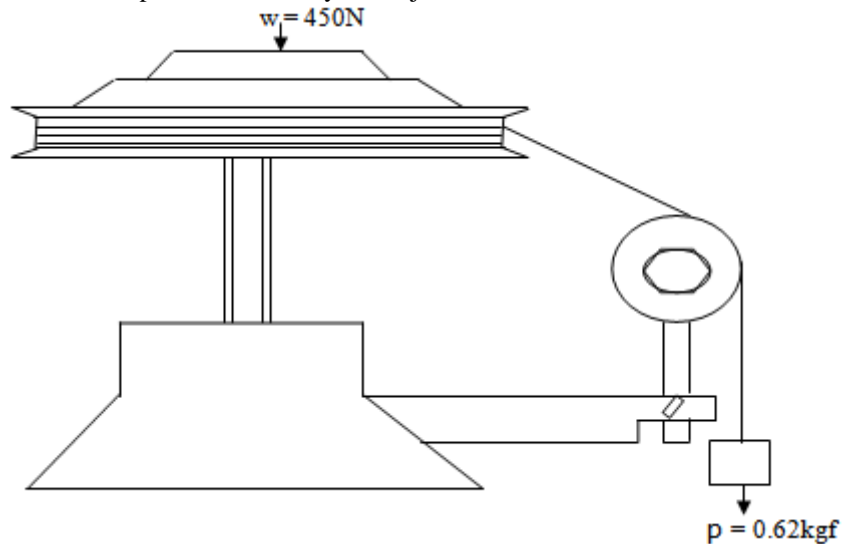

Figure 1

EXPERIMENT 1 OBSERVED DATA:

Diameter of turn-table,  $D = 22.6\text{cm} = 226\text{mm}$

Pitch of screw thread,  $P_T = 3.2\text{mm}$

Load,  $W = 450\text{N}$

Effort,  $P = 0.62\text{kg} \times 10^1\text{m/s} = 6.2\text{N}$

Distance moved by load,  $Y = 0.32\text{cm} = 3.2\text{mm}$

Distance moved by effort,  $X = 72.0\text{cm} = 720\text{mm}$

Where;  $1\text{kg} = 10\text{N}$

$$0.62\text{kg} = x\text{N}$$

$$x\text{N} = \frac{0.62 \times 10}{1\text{kg}}$$

Mechanical Advantage,  $M.A = \frac{\text{Load, } W}{\text{Effort, } P}$

$$= \frac{450}{6.2}$$

$$M.A = 72.58$$

Velocity Ratio,  $V.R = \frac{\text{Distance moved by effort, } x}{\text{Distance moved by load, } y}$

$$V.R_{\text{Approx}} = \frac{720}{3.2} \\ = 225.00$$

$V.R_{\text{True}} = \frac{\text{circumference of turn-table}}{\text{Pitch}}$

$$= \frac{\pi D}{p} = \frac{22 \times 226}{7 \times 3.2} \\ = V.R_{\text{True}} = 221.96$$

$$\text{Efficiency } \eta_{\text{Approx}} = \frac{M.A}{V.R_{\text{Approx}}} \times 100 = \frac{72.58}{225} \times 100$$

$$\eta_{\text{Approx}} = \frac{72.58}{225} = 32.26\%$$

$$\text{Efficiency } \eta_{\text{True}} = \frac{M.A}{V.R_{\text{True}}} \times 100 = \frac{72.58}{221.96} \times 100$$

$$\eta_{\text{True}} = \frac{72.58}{221.96} = 32.7\%$$

Frictional loss is given as:

$$F_L = 1 - \text{Efficiency, } \eta$$

$$F_{L\text{Approx}} = 1 - \eta_{\text{Approx}} = 1 - \frac{32.26}{100} \\ = 1 - 0.3226 = 0.6774$$

$$F_{L\text{Approx}} = 0.68$$

$$F_{L\text{True}} = 1 - \eta_{\text{True}} = 1 - \frac{32.7}{100} \\ = 1 - 0.327 = 0.673$$

$$F_{L\text{True}} = 0.67$$

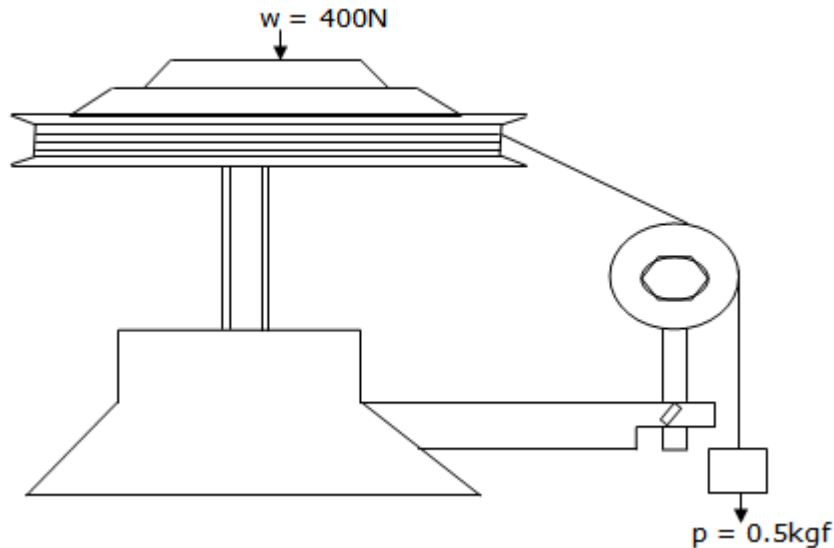

Figure 2

**Experiment 2 Observed Data:**

Diameter of turntable,  $D = 226\text{mm}$

Pitch of screw thread,  $P_T = 3.2\text{mm}$

Load,  $W = 400\text{N}$

Distance moved by load,  $Y = 3.2\text{mm}$

Distance moved by effort,  $X = 70.3\text{cm} = 703\text{mm}$

$$M.A = \frac{W}{P} = \frac{400}{5}$$

$$M.A = 80$$

$$V.R_{\text{Approx}} = \frac{X}{Y} = \frac{703}{3.2}$$

$$V.R_{\text{Approx}} = 219.69$$

$$V.R_{\text{True}} = 221.96$$

$$\eta_{\text{Approx}} = \frac{M.A}{V.R_{\text{Approx}}} \times 100 = \frac{80}{219.69} \times 100 \\ = \frac{8000}{219.69}$$

$$\eta_{\text{Approx}} = 36.41\%$$

$$\eta_{\text{True}} = \frac{M.A}{V.R_{\text{True}}} \times 100 = \frac{80}{221.96} \times 100 \\ = \frac{8000}{221.96}$$

$$\eta_{\text{True}} = 36.04\%$$

Frictional loss,  $F_L = 1 - \eta$

$$F_{L\text{Approx}} = 1 - \eta_{\text{Approx}} = 1 - \frac{36.41}{100} \\ = 1 - 0.3641 = 0.6359$$

$$F_{L\text{Approx}} = 0.64$$

$$F_{L\text{True}} = 1 - \eta_{\text{True}} = 1 - \frac{36.04}{100}$$

$$= 1 - 0.3604 = 0.6396$$

$$F_{L\text{True}} = 0.64$$

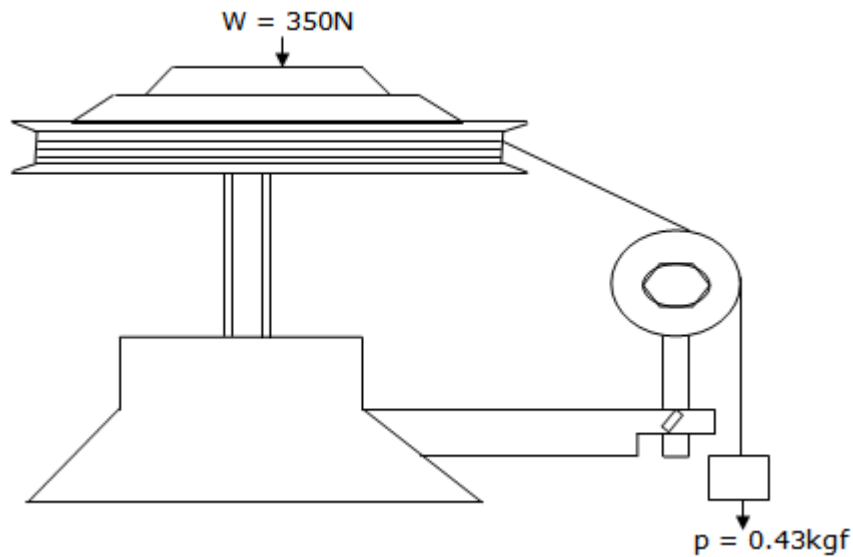

Figure3

**Experiment 3 Observed Data**

Diameter of turn-table,  $D = 226\text{mm}$

Pitch of screw thread,  $P_T = 3.2\text{mm}$

Load,  $W = 350\text{N}$

Effort,  $P = 0.43 \times 10 = 4.3\text{N}$

Distance moved by load,  $y = 3.2\text{mm}$

Distance moved by effort,  $x = 70.3\text{cm} = 703\text{mm}$

$$M.A = \frac{W}{P} = \frac{350}{4.3}$$

$$M.A = 81.4$$

$$V.R_{\text{Approx}} = \frac{x}{y} = \frac{703}{3.2}$$

$$V.R_{\text{Approx}} = 219.69$$

$$V.R_{\text{True}} = 221.96$$

$$\eta_{\text{Approx}} = \frac{M.A}{V.R_{\text{Approx}}} \times 100 = \frac{81.40}{219.69} \times 100$$

$$= \frac{8140}{219.69}$$

$$\eta_{\text{Approx}} = 37.05\%$$

$$\eta_{\text{True}} = \frac{M.A}{V.R_{\text{True}}} \times 100 = \frac{81.40}{221.96} \times 100$$

$$= \frac{8140}{221.96}$$

$$\eta_{\text{True}} = 36.67\%$$

$$F_{L\text{Approx}} = 1 - \eta_{\text{Approx}} = 1 - \frac{37.05}{100}$$

$$= 1 - 0.3705 = 0.6295$$

$$F_{L\text{Approx}} = 0.63$$

$$F_{L\text{True}} = 1 - \eta_{\text{True}} = 1 - \frac{36.67}{100}$$

$$= 1 - 0.3667 = 0.6333$$

$$F_{L\text{True}} = 0.63$$

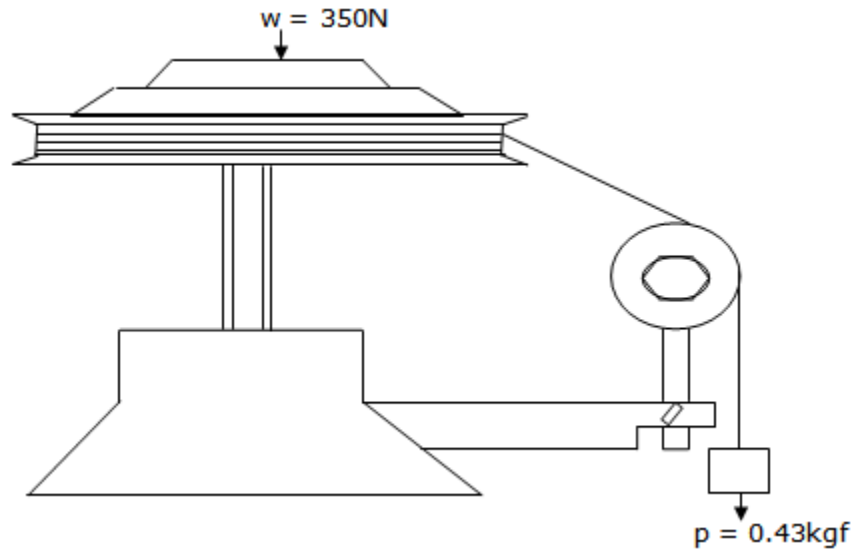

Figure 4

**Experiment 4 Observed Data**

Diameter of turn-table,  $D = 226\text{mm}$

Pitch of screw thread,  $P_T = 3.2\text{mm}$

Load,  $W = 300\text{N}$

Effort,  $P = 0.36 \times 10 = 3.6\text{N}$

Distance moved by load,  $y = 3.2\text{mm}$

Distance moved by effort,  $x = 68.5\text{cm} = 685\text{mm}$

$$M.A = \frac{W}{P} = \frac{300}{3.6}$$

$$M.A = 83.33$$

$$V.R_{\text{Approx}} = \frac{x}{y} = \frac{685}{3.2}$$

$$V.R_{\text{Approx}} = 214.06$$

$$V.R_{\text{True}} = 221.96$$

$$\eta_{\text{Approx}} = \frac{M.A}{V.R_{\text{Approx}}} \times 100 = \frac{83.33}{214.06} \times 100$$

$$= \frac{8333}{21406}$$

$$\eta_{\text{Approx}} = 38.93\%$$

$$\eta_{\text{True}} = \frac{M.A}{V.R_{\text{True}}} \times 100 = \frac{83.33}{221.96} \times 100$$

$$= \frac{8333}{22196}$$

$$\eta_{\text{True}} = 37.54\%$$

$$F_{L\text{Approx}} = 1 - \eta_{\text{Approx}} = 1 - \frac{38.93}{100}$$

$$= 1 - 0.3893 = 0.6107$$

$$F_{L\text{Approx}} = 0.61$$

$$F_{L\text{True}} = 1 - \eta_{\text{True}} = 1 - \frac{37.54}{100}$$

$$= 1 - 0.3754 = 0.6246$$

$$F_{L\text{True}} = 0.62$$

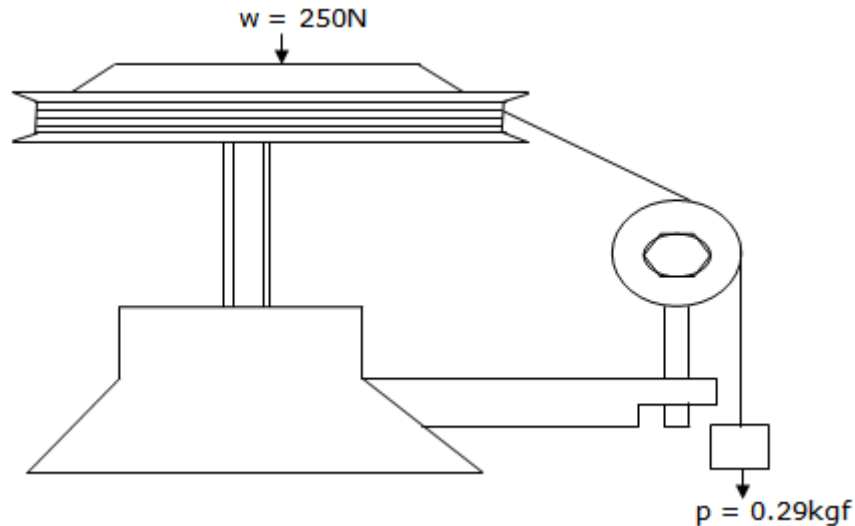

Figure 5

**Experiment 5 Observed Data**

Diameter of turn-table,  $D = 226\text{mm}$

Pitch of screw thread,  $P_T = 3.2\text{mm}$

Load,  $W = 250\text{N}$

Effort,  $P = 0.29 \times 10 = 2.9\text{N}$

Distance moved by load,  $y = 3.2\text{mm}$

Distance moved by effort,  $x = 69.5\text{cm} = 695\text{mm}$

$$M.A = \frac{W}{P} = \frac{250}{2.9}$$

$$M.A = 86.21$$

$$V.R_{\text{Approx}} = \frac{x}{y} = \frac{695}{3.2}$$

$$V.R_{\text{Approx}} = 217.19$$

$$V.R_{\text{True}} = 221.96$$

$$\eta_{\text{Approx}} = \frac{M.A}{V.R_{\text{Approx}}} \times 100 = \frac{86.21}{217.19} \times 100$$

$$= \frac{8621}{217.19}$$

$$\eta_{\text{Approx}} = 39.69\%$$

$$\eta_{\text{True}} = \frac{M.A}{V.R_{\text{True}}} \times 100 = \frac{86.21}{221.96} \times 100$$

$$= \frac{8621}{221.96}$$

$$\eta_{\text{True}} = 38.84\%$$

$$F_{L\text{Approx}} = 1 - \eta_{\text{Approx}} = 1 - \frac{39.69}{100}$$

$$= 1 - 0.3969 = 0.6031$$

$$F_{L\text{Approx}} = 0.60$$

$$F_{L\text{True}} = 1 - \eta_{\text{True}} = 1 - \frac{38.84}{100}$$

$$= 1 - 0.3884 = 0.6116$$

$$F_{L\text{True}} = 0.61$$

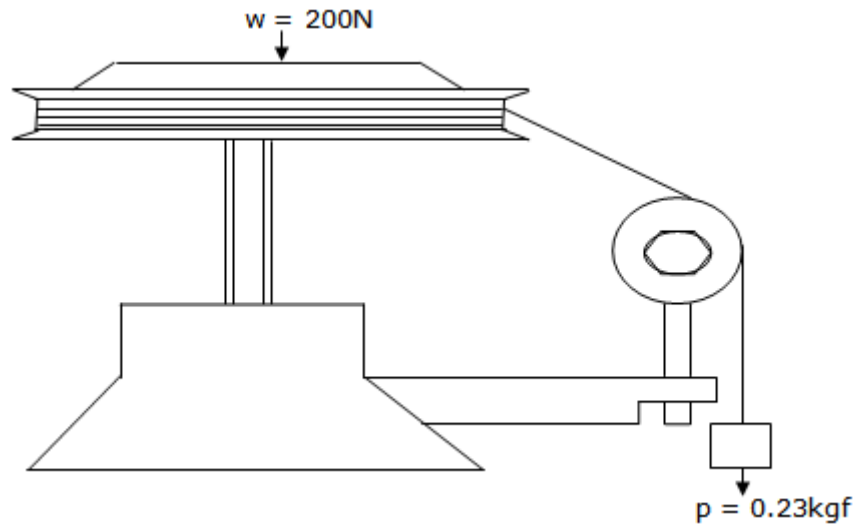

Figure 6

**Experiment 6 Observed Data**

Diameter of turn-table,  $D = 226\text{mm}$

Pitch of screw thread,  $P_T = 3.2\text{mm}$

Load,  $W = 200\text{N}$

Effort,  $P = 0.23 \times 10 = 2.3\text{N}$

Distance moved by load,  $y = 3.2\text{mm}$

Distance moved by effort,  $x = 67.0\text{cm} = 670\text{mm}$

$$M.A = \frac{W}{P} = \frac{200}{2.3}$$

$$M.A = 86.96$$

$$V.R_{\text{Approx}} = \frac{x}{y} = \frac{670}{3.2}$$

$$V.R_{\text{Approx}} = 209.38$$

$$V.R_{\text{True}} = 221.96$$

$$\eta_{\text{Approx}} = \frac{M.A}{V.R_{\text{Approx}}} \times 100 = \frac{86.96}{209.38} \times 100$$

$$= \frac{8696}{20938}$$

$$\eta_{\text{Approx}} = 41.53\%$$

$$\eta_{\text{True}} = \frac{M.A}{V.R_{\text{True}}} \times 100 = \frac{86.96}{221.96} \times 100$$

$$= \frac{8696}{22196}$$

$$\eta_{\text{True}} = 39.18\%$$

$$F_{L\text{Approx}} = 1 - \eta_{\text{Approx}} = 1 - \frac{41.53}{100}$$

$$= 1 - 0.4153 = 0.5847$$

$$F_{L\text{Approx}} = 0.59$$

$$F_{L\text{True}} = 1 - \eta_{\text{True}} = 1 - \frac{39.18}{100}$$

$$= 1 - 0.3918 = 0.6082$$

$$F_{L\text{True}} = 0.61$$

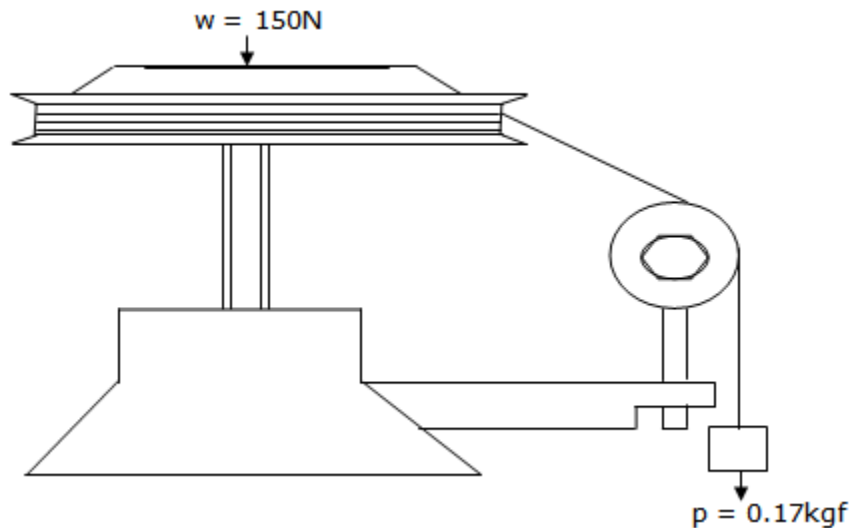

Figure 7

**Experiment 7 Observed Data**

Diameter of turn-table,  $D = 226\text{mm}$

Pitch of screw thread,  $P_T = 3.2\text{mm}$

Load,  $W = 150\text{N}$

Effort,  $P = 0.17 \times 10 = 1.7\text{N}$

Distance moved by load,  $y = 3.2\text{mm}$

Distance moved by effort,  $x = 67.0\text{cm} = 670\text{mm}$

$$M.A = \frac{W}{P} = \frac{150}{1.7}$$

$$M.A = 88.24$$

$$V.R_{\text{Approx}} = \frac{x}{y} = \frac{670}{3.2}$$

$$V.R_{\text{Approx}} = 209.38$$

$$V.R_{\text{True}} = 221.96$$

$$\eta_{\text{Approx}} = \frac{M.A}{V.R_{\text{Approx}}} \times 100 = \frac{88.24}{209.38} \times 100$$

$$= \frac{8824}{20938}$$

$$\eta_{\text{Approx}} = 42.14\%$$

$$\eta_{\text{True}} = \frac{M.A}{V.R_{\text{True}}} \times 100 = \frac{88.24}{221.96} \times 100$$

$$= \frac{8824}{22196}$$

$$\eta_{\text{True}} = 39.75\%$$

$$F_{L\text{Approx}} = 1 - \eta_{\text{Approx}} = 1 - \frac{42.14}{100}$$

$$= 1 - 0.4214 = 0.5786$$

$$F_{L\text{Approx}} = 0.58$$

$$F_{L\text{True}} = 1 - \eta_{\text{True}} = 1 - \frac{39.75}{100}$$

$$= 1 - 0.3975 = 0.6025$$

$$F_{L\text{True}} = 0.60$$



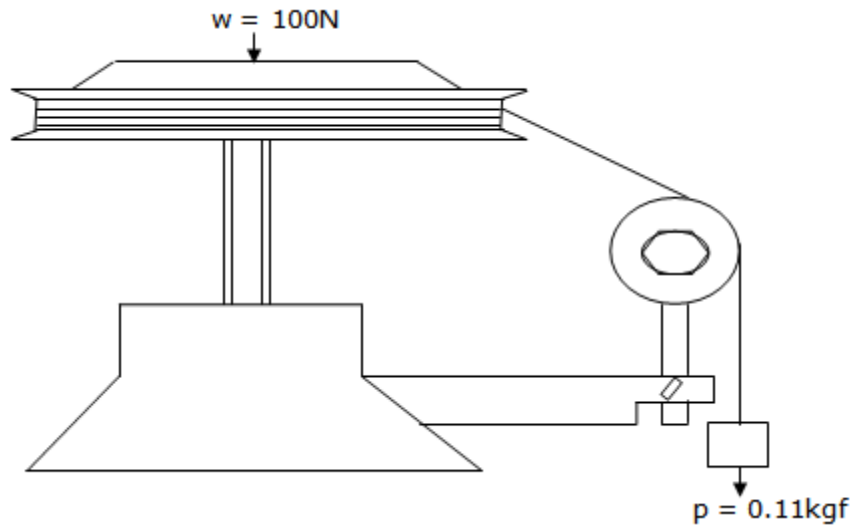

Figure 8

**Experiment 8 Observed Data**

Diameter of turn-table,  $D = 226\text{mm}$

Pitch of screw thread,  $P_T = 3.2\text{mm}$

Load,  $W = 100\text{N}$

Effort,  $P = 0.11 \times 10 = 1.10\text{N}$

Distance moved by load,  $y = 3.2\text{mm}$

Distance moved by effort,  $x = 68.5\text{cm} = 685\text{mm}$

$$M.A = \frac{W}{P} = \frac{100}{1.10}$$

$$M.A = 90.91$$

$$V.R_{\text{Approx}} = \frac{x}{y} = \frac{685}{3.2}$$

$$V.R_{\text{Approx}} = 214.06$$

$$V.R_{\text{True}} = 221.96$$

$$\eta_{\text{Approx}} = \frac{M.A}{V.R_{\text{Approx}}} \times 100 = \frac{90.91}{214.06} \times 100$$

$$= \frac{90.91}{214.06}$$

$$\eta_{\text{Approx}} = 42.47\%$$

$$\eta_{\text{True}} = \frac{M.A}{V.R_{\text{True}}} \times 100 = \frac{90.91}{221.96} \times 100$$

$$= \frac{90.91}{221.96}$$

$$\eta_{\text{True}} = 40.96\%$$

$$F_{L\text{Approx}} = 1 - \eta_{\text{Approx}} = 1 - \frac{42.47}{100}$$

$$= 1 - 0.4247 = 0.5753$$

$$F_{L\text{Approx}} = 0.58$$

$$F_{L\text{True}} = 1 - \eta_{\text{True}} = 1 - \frac{40.96}{100}$$

$$= 1 - 0.4096 = 0.5904$$

$$F_{L\text{True}} = 0.59$$

Table 1: Test Analysis Results Obtained At Different Loads.

Load W(N)	Effort P (N)	Dist. moved by load Y (mm)	Dist. moved by effort X (mm)	M.A ( $\frac{N}{W}$ )	Velocity Ratio; V.R ( $\frac{mm}{mm}$ )		Efficiency, $\eta$ (%)		Frictional Loss, $F_f$	
					Approx.	True	Approx.	True	Approx.	True
450	6.20	3.20	720.00	72.58	225.00	221.96	32.26	32.70	0.68	0.67
400	5.00	3.20	703.00	80.00	219.69	221.96	36.41	36.04	0.64	0.64
350	4.30	3.20	703.00	81.40	219.69	221.96	37.05	36.67	0.63	0.63
300	3.60	3.20	685.00	83.33	214.06	221.96	38.93	37.54	0.61	0.62
250	2.90	3.20	695.00	86.21	217.19	221.96	39.69	38.84	0.60	0.61
200	2.30	3.20	670.00	86.96	209.38	221.96	41.53	39.18	0.59	0.61
150	1.70	3.20	670.00	88.24	209.38	221.96	42.14	39.75	0.58	0.60
100	1.10	3.20	685.00	90.91	214.06	221.96	42.47	40.96	0.58	0.59

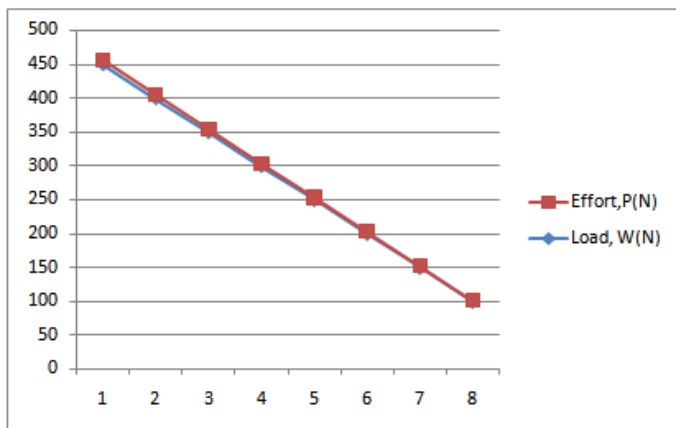

Figure 9

Figure 9: A graph of load Vs Effort

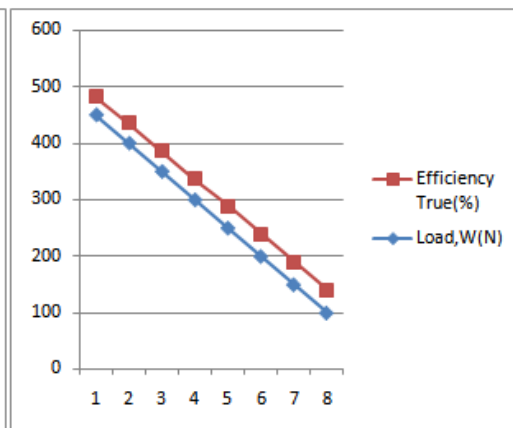

Figure 10

Figure 10: A graph of Load Vs Efficiency(True)

From the graph of load, W against effort, P:

$$\begin{aligned}
 \text{Slope, } S &= \frac{\Delta W}{\Delta P} = \frac{W_2 - W_1}{P_2 - P_1} \\
 &= \frac{400 - 150}{5.00 - 1.70} \\
 &= \frac{250}{3.30} \\
 S &= 75.76
 \end{aligned}$$

The slope, S of the graph of load, W against effort, P is defined as the Force Ratio or Mechanical Advantage.

Mathematically:

$$\text{Slope, } S = \frac{\Delta W}{\Delta P} = \text{Mechanical Advantage, M.A}$$

#### IV. Results And Discussion

Eight consecutive experiments were done at different loads with pitch of the screw thread constant and equal to the distance moved by the load, i.e.,  $P_T = 3.2\text{mm}$  and the diameter of the turn-table also constant at  $D = 226\text{mm}$ . The values of the Mechanical Advantage, Velocity Ratio and Mechanical Efficiency were obtained.

Table 1.0 shows the test analysis results obtained.

The relationship between the efficiency and the load, the effort against the load as displayed graphically shows that decrease in load causes increase in efficiency and increase in load causes increase in effort applied (figure 9, figure 10).

It is evident that, the machine was most efficient not constant due to the different loading condition and the frictional forces induced between the screw and the threaded base. The efficiency of a screw jack is always less than 50% because the ratio of the Mechanical Advantage, to the Velocity Ratio is less than half i.e.

$\frac{M.A}{V.R} > \frac{1}{2}$  or the pitch of the screw thread is small.

$V.R > 2$

The variation between the approximate and true values of velocity ratios cannot be negligible. Finally, the sources of errors that may be possible from the experiment are; alignment error between the scale rule and the rope or cord and also, parallax error.

## **V. Conclusion**

From the graphs of Figure 9 and Figure 10, it has been established that the relationship between the load and efficiency, and between the load and effort applied is linear and was also discovered that decrease in load means decrease in effort and decrease in load causes increase in efficiency.

## **References**

- [1]. Ivan Sunit Rout, Dipti Ranjan Patra, Sidhartha Sankar Padhi, Jitendra Narayan Biswal, Turshar Kanti Panda, Design and Fabrication of motorized automated Object lifting Jack, International Organization of Scientific Research Journal of Engineering, Vol.04, Issue 05 (May.2014) PP 06-12
- [2]. A.S Akinwonmi and A. Mohammed, Modification of Existing Design of a Car Jack, Journal of Emerging Trends in Engineering and Applied Sciences, 3(4), 2012, 581-588
- [3]. M.M. Noor, K. Kadirgama and M.M Rahman, Analysis of Auto Car Jack, National Conference in Mechanical Engineering Reseach and Postgraduate Students FKM Conference Hall, UMP, Kuantan, Pahang, Malaysia, 26-27 May 2010, 198-203
- [4]. P.S. Rana, P.H Belge, N.A. Nagrare, C.A. Padwad, P.R Daga, K.B Deshbhratar and N.K Mandavgade, European Journal of Applied Engineering and Scientific Research, 1(4), 2012, 167-172
- [5]. Fedinand, B.(2008): Vector Mechanics for Engineers, McGraw-Hill Publishing Company, Limited New Delhi, Stata