

“Investigation of Structural Analysis of Composite Beam Having I- Cross Section under Transverse Loading”

Ashish A. Desai , Prof. Chhapkhane N.K.
Rajarambapu Institute of Technology, Sakharale

Abstract: - In structural applications, beam is one of the most common structural members that have been considered in design. This paper is intended to provide tools that ensure better designing options for composite laminates of I-beam. In this Paper an analytical method & FEM approach calculating axial stiffness , Axial stress ,Axial strain of flange and web laminates. The results show the stacking sequence and fiber angle orientation strongly affects strength of composite I-beam.

I. Introduction :-

A composite material or a compound is a mixture of two or more distinct constituents which remain independent at the macroscopic level when they become part of a structure. The main advantages for the use composite materials are high strength , high stiffness to weight ratio, long fatigue life, resistance to electrochemical corrosion, and other superior material properties of composites.

Those advantages are why composite materials are used in many fields of industry. Composites are widely used in the automobile, aerospace, and athletics industry. Examples of composites include bumpers, wings, bicycle frames, and downhill skis. Combined with the low weight and high strength characteristics of composite materials, the ability to optimize a composite structure for a specific property is useful to a design engineer.

II. Present Theories & Practices:

W. S. Chan et al. [1] focused a simple method based on classical lamination theory & determine the locations of the centroid and the shear center for composite beams with box cross-section. They analyzed aluminum beams with five web angles in both symmetric and unsymmetrical layups. For a symmetrical laminate layup of box beams, the both centroid and shear center locations move toward the bottom flange laminates as web angle is increased. For box beam with 90^0 web angle (a squared box beam), locations of centroid and shear center are coincided at its geometric center of cross-section. For an unsymmetrical laminate layup of box beam, the centroid location is closer to the bottom flange laminate comparing to the symmetric case. However, the shear center location is further from the bottom flange laminate.

Y.X. Zhang et al. [2] studied on the recent development of the finite element analysis for laminated composite plates. The recent advances of Finite element analysis of composite laminated plate based on various lamination theories, with the focus on the theories for the buckling and post-buckling analysis, geometric non-linearity , large deformation analysis, failure and damage analysis of composite laminated plates. They concluded that, the composite material nonlinearity had significant effects on the geometrically nonlinearity, structural buckling load, post buckling structural stiffness, and structural failure mode shape of composite laminate plates and shells.

Jun Deng et al. [3] presented on stress analysis of steel beams reinforced with a bonded CFRP (Carbon Fiber Reinforced Polymers) Plate. The analysis included the analytical solution to calculate the stresses in the reinforced beam under mechanical as well as thermal loads. The solution has been extended by a numerical procedure to CFRP plates with tapered ends, which can significantly reduce the stress concentration. Finite element analysis was employed to validate the analytical results, and a parametric study was carried out to show how the maximum stresses have been influenced by the dimensions and the material properties of the adhesive and the adherents.

Uttam Kumar Chakravarty et al. [4] have investigated on the modeling of composite beam cross-sections. Theoretical models are available for simple composite beam cross-sections. But computational technique, such as finite element analysis (FEA), is considered for complex composite beam cross-sections. It is found that variational asymptotic beam sectional analysis (VABS) and boundary element method (BEM) are very popular and computationally efficient models for composite beam cross-sectional analysis.

III. Methodology & Approach :-

The finite element method is used to simulate the response of a composite laminate. To validate the model, ANSYS 13 is used to solve examples. A four-layer symmetric of flange & web laminate with a

different layup , axial loading condition. The problem is first solved analytically and then with the finite element method. The result is compared to show the accuracy of the model.

3.1 Analytical analysis of composite beam:-

The following equations are used to calculate the elastic properties of an angle ply lamina in which continuous fibers are aligned at an angle θ with the positive x direction.

$$\frac{1}{E_{11}} = \frac{\cos^4 \theta}{E_X} + \frac{\sin^4 \theta}{E_Y} + \frac{1}{4} \left(\frac{1}{G_{XY}} - \frac{2\nu_{xy}}{E_X} \right) \sin^2 2\theta$$

$$\frac{1}{E_{22}} = \frac{\sin^4 \theta}{E_X} + \frac{\cos^4 \theta}{E_Y} + \frac{1}{4} \left(\frac{1}{G_{XY}} - \frac{2\nu_{xy}}{E_X} \right) \sin^2 2\theta$$

$$\frac{1}{G_{12}} = \frac{1}{E_X} + \frac{2\nu_{XY}}{E_X} + \frac{1}{E_Y} - \left(\frac{1}{E_X} + \frac{2\nu_{12}}{E_X} + \frac{1}{E_Y} - \frac{1}{G_{XY}} \right) \cos^2 2\theta$$

$$\nu_{12} = E_{11}$$

3.2 Elemental Stiffness Matrix:-

$$Q = \begin{bmatrix} Q_{11} & Q_{12} & Q_{16} \\ Q_{21} & Q_{22} & Q_{26} \\ Q_{61} & Q_{62} & Q_{66} \end{bmatrix}$$

$$Q_{11} = \frac{E_{11}}{1 - \nu_{12} \nu_{21}}$$

$$Q_{22} = \frac{E_{22}}{1 - \nu_{12} \nu_{21}}$$

$$Q_{12} = \frac{\nu_{12} E_{22}}{1 - \nu_{12} \nu_{21}}$$

$$Q_{66} = G_{12}$$

3.3 \bar{Q} Matrix

Using trigonometric identities, Tsai and Pagano have shown that the Elements in the \bar{Q} matrix can be written as,

$$\bar{Q} = \begin{bmatrix} \bar{Q}_{11} & \bar{Q}_{12} & \bar{Q}_{16} \\ \bar{Q}_{21} & \bar{Q}_{22} & \bar{Q}_{26} \\ \bar{Q}_{31} & \bar{Q}_{32} & \bar{Q}_{66} \end{bmatrix}$$

Where,

$$\bar{Q}_{11} = Q_{11} \cos^4 \theta + 2(Q_{12} + 2Q_{66}) \sin^2 \theta \cos^2 \theta + Q_{22} \sin^4 \theta$$

$$\bar{Q}_{12} = (Q_{11} + Q_{22} - 4Q_{66}) \sin^2 \theta \cos^2 \theta + Q_{12} (\sin^4 \theta + \cos^4 \theta)$$

$$\bar{Q}_{22} = Q_{11} \sin^4 \theta + 2(Q_{12} + 2Q_{66}) \sin^2 \theta \cos^2 \theta + Q_{22} \cos^4 \theta$$

$$\bar{Q}_{16} = (Q_{12} - Q_{12} - 2Q_{66}) \sin \theta \cos^3 \theta + (Q_{12} - Q_{22} + 2Q_{66}) \sin^3 \theta \cos \theta$$

$$\bar{Q}_{26} = (Q_{11} - Q_{12} - 2Q_{66}) \sin^3 \theta \cos \theta + (Q_{12} - Q_{22} + 2Q_{66}) \sin \theta \cos^3 \theta$$

$$\bar{Q}_{66} = (Q_{11} + Q_{22} - 2Q_{12} - 2Q_{66}) \sin^2 \theta \cos^2 \theta + Q_{66} (\sin^4 \theta + \cos^4 \theta)$$

3.3 Stress & strain of layer of flange & web Laminates using Axial stiffness :-

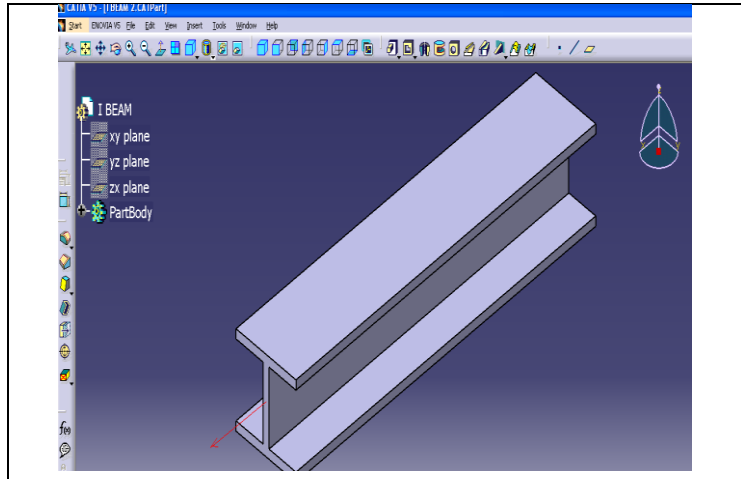

Fig 1 :- I–section Composite Beam with symmetrical Flange section (RED arrow indicates axial force which is acting at centroid)

Consider a load, P acting at the centroid , such that the equivalent axial stiffness is, Therefore,

$$P = \bar{N}_x = \bar{E} \bar{A} \epsilon_x^c$$

For flange of forces & moments per width ,

$$N_{X1} = A_{1,f} * \epsilon_x^c$$

$$M_{X1} = B_{1,f} * \epsilon_x^c$$

$$M_{XY1} = -\frac{1}{d_{66}} [(b_{16}) X N_{X1} + (b_{16}) X M_{X1}]$$

For Web of forces & moments per width ,

$$N_{X1} = A_{1,f} * \epsilon_x^c$$

$$M_{X1} = B_{1,f} * \epsilon_x^c$$

$$M_{XY1} = 0 \text{ ----- (web is symmetrical)}$$

3.4. Constitutive Equation of Laminate :-

The stress- strain relations for general Orthotropic lamina can be written as,

$$\begin{bmatrix} \sigma_x \\ \sigma_y \\ \tau_{xy} \end{bmatrix} = [\bar{Q}] \begin{bmatrix} \epsilon_x \\ \epsilon_y \\ \gamma_{xy} \end{bmatrix}$$

$[\bar{Q}]$ represents the stiffness matrix for the Lamina.

The stresses in the Kth ply at a distance of Z_k from the reference plane in terms of strains and laminate curvatures can be expressed as,

$$\begin{bmatrix} \sigma_x \\ \sigma_y \\ \tau_{xy} \end{bmatrix} = \begin{bmatrix} \bar{Q}_{11} & \bar{Q}_{12} & \bar{Q}_{16} \\ \bar{Q}_{21} & \bar{Q}_{22} & \bar{Q}_{26} \\ \bar{Q}_{31} & \bar{Q}_{32} & \bar{Q}_{66} \end{bmatrix} \begin{bmatrix} \epsilon_x \\ \epsilon_y \\ \gamma_{xy} \end{bmatrix}$$

Where,
$$\begin{bmatrix} \varepsilon_x \\ \varepsilon_y \\ \gamma_{xy} \end{bmatrix} = \begin{pmatrix} \varepsilon_x^0 \\ \varepsilon_y^0 \\ \gamma_{xy}^0 \end{pmatrix} + z_k \begin{pmatrix} k_x \\ k_y \\ k_{xy} \end{pmatrix}$$

$$\begin{bmatrix} \sigma_x \\ \sigma_y \\ \tau_{xy} \end{bmatrix} = \begin{bmatrix} \bar{Q}_{11} & \bar{Q}_{12} & \bar{Q}_{16} \\ \bar{Q}_{21} & \bar{Q}_{22} & \bar{Q}_{26} \\ \bar{Q}_{31} & \bar{Q}_{32} & \bar{Q}_{66} \end{bmatrix} \left\{ \begin{pmatrix} \varepsilon_x^0 \\ \varepsilon_y^0 \\ \gamma_{xy}^0 \end{pmatrix} + z_k \begin{pmatrix} k_x \\ k_y \\ k_{xy} \end{pmatrix} \right\}$$

The strains in the laminate vary linearly through the thickness whereas the stresses vary discontinuously. This is due to the different material properties of the layer resulting from different fiber orientation.

Computing Axial stiffness for composite Beam: -

$$(EA)_{BEAM} = \frac{d_{11}}{a_{11}d_{11} - b_{11}^2}$$

IV. Analytical analysis of steel & Aluminum:-

Axial stress : - $\sigma = P / A$

Axial stiffness = $\frac{F}{\delta}$

where, δ = deflection = $\varepsilon L = \frac{\sigma l}{E} = \frac{Pl}{EA}$

V. Material Properties :-

Contain	Carbon Epoxy	Glass Epoxy	Steel	Al
E ₁₁	126.9 GPa	40.3 GPa	210 GPa	69 Gpa
E ₁₂	11 GPa	6.21 GPa	-	-
G ₁₂	6.6 GPa	3.07 GPa	80 GPa	26.5 GPa
μ_{12}	0.2	0.2	0.3	0.3
Density Kg/m ³	1610	1910	7810	2700

Table 1:- Material Properties

VI. Finite Element Method :-

In this method all the complexities of the problems, like varying shape, boundary conditions and loads are maintained as they are but the solutions obtained are approximate. Because of its diversity and flexibility as an analysis tool, it is receiving much attention in engineering. The fast improvements in computer hardware technology and slashing of cost of computers have boosted this method since the computer is the basic need for the application of this method. A number of popular brand of finite element analysis packages are now available commercially. Some of the popular packages are STAAD-PRO, GT-STRUDEL, NASTRAN, NISA and ANSYS. Using these packages one can analyze several complex structures.

VII. Finite Element Analysis :-

With different fiber angle orientation and Stacking sequence the analysis done in ANSYS 13.0 version for following dimension of I- composite Material and steel beam. The problem is first solved analytically and then with the finite element method. For that geometry

(Refer fig 1.) to assume that $b_{f1} = 100\text{mm}$, $b_{f2} = 100\text{ mm}$, $h_w = 80\text{ mm}$, $t_1 = t_2 = t_3 = 10\text{ mm}$, Length of the Beam is 500 mm, Applied axial force at centroid is 5000 N.

For composite beam , four-layer symmetric of flange & web laminate with a layup & axial loading condition. (One HM Carbon Epoxy layer and remaining three layers are Glass epoxy & Thickness of layers are $T_1=4.5\text{ mm}$, $T_2=0.5\text{ mm}$, $T_3=0.5\text{ mm}$, $T_4=0.5\text{ mm}$.)

7.1 SHELL 181 ELEMENT :-

Shell 181 suitable for analyzing thin to moderately-thick shell structures. It is a four-node element with six degrees of freedom at each node: translations in the x, y, and z directions, and rotations about the x, y, and z-axes. (If the membrane option is used, the element has translational degrees of freedom only). The element provides options for unrestrained warping and restrained warping of cross-sections. The accuracy in modeling composite shells is governed by the first-order shear-deformation theory (usually referred to as Mindlin-Reissner shell theory). The element formulation is based on logarithmic strain and true stress measures. The element kinematics allow for finite membrane strains (stretching).

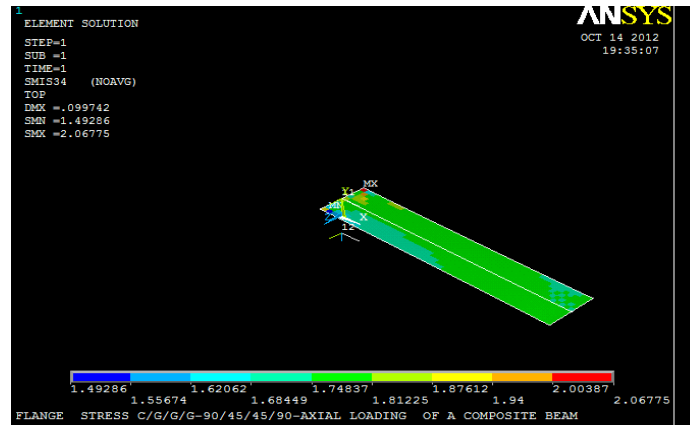

Fig.2. ANSYS Results for Flange - axial stress of Composite I-Beam

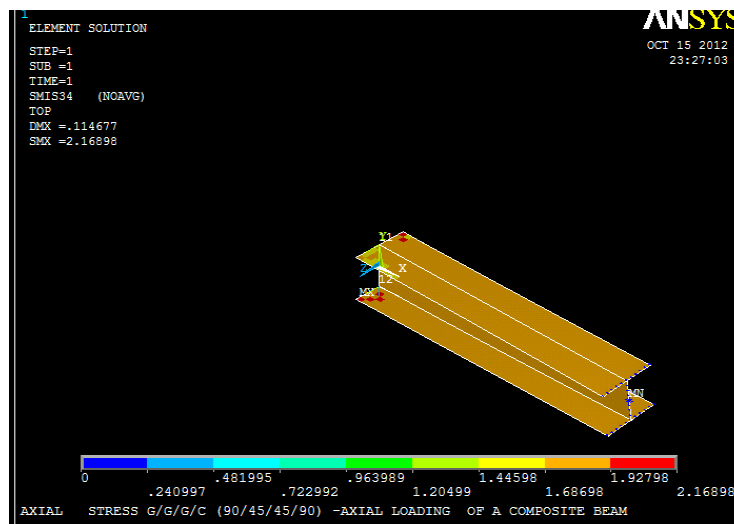

Fig.3. ANSYS Results for Axial stress of Composite I-Beam

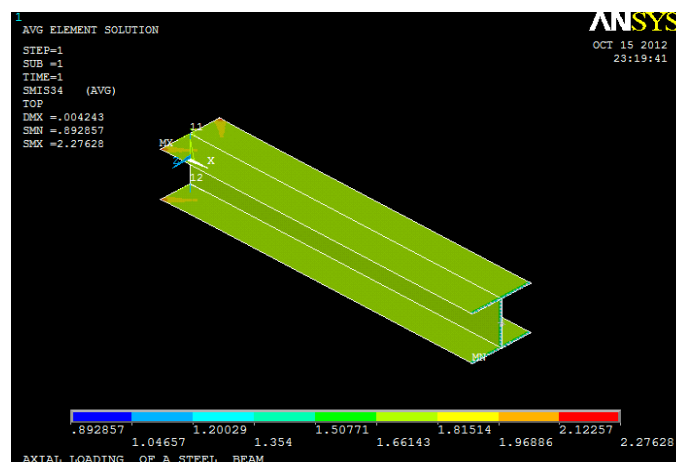

Fig.4. ANSYS Results for Axial stress of steel I-Beam

VIII. Result & Discussion :-

For optimum composite I-section composite beam , obtained by changing orientation of stacking sequence & Orientation angle. For this purpose, stacking sequence of Carbon Epoxy & Glass Epoxy material is used . To verify the analytical results & ANSYS Result .

Stacking sequence	Fiber orientation angle	Flange stress (N/mm ²)	Web stress (N/mm ²)	Flange strain	Web Strain
C/G/G/G	90 ⁰ /45 ⁰ / 45 ⁰ /90 ⁰	2.28	2.29	0.000042	0.000043
G/C/G/G	90 ⁰ /45 ⁰ / 45 ⁰ /90 ⁰	2.61	2.65	0.000086	0.0000831
G/G/C/G	90 ⁰ /45 ⁰ / 45 ⁰ /90 ⁰	2.61	2.65	0.000086	0.0000831
G/G/G/C	90 ⁰ /45 ⁰ / 45 ⁰ /90 ⁰	2.28	2.29	0.000042	0.000043

Table 2 :-Analytical results for axial stress & strain in flange & web for composite I- beam.

Stacking sequence	Fiber orientation angle	Flange stress (N/mm ²)	Web stress (N/mm ²)	Flange strain	Web Strain
C/G/G/G	90 ⁰ /45 ⁰ / 45 ⁰ /90 ⁰	2.06	1.9	0.000036	0.000047
G/C/G/G	90 ⁰ /45 ⁰ / 45 ⁰ /90 ⁰	2.1	2.21	0.000066	0.000077
G/G/C/G	90 ⁰ /45 ⁰ / 45 ⁰ /90 ⁰	2.11	2.8	0.000064	0.000077
G/G/G/C	90 ⁰ /45 ⁰ / 45 ⁰ /90 ⁰	2.85	2.56	0.000034	0.000047

Table 3 :-ANSYS -13 results for axial stress & strain flange & web for composite I- beam.

Types of I-section Beam	Applied Load In(N)	ANSYS Result (N/mm ²)	Axial stiffness (N/mm)	Weight in kg.
Steel I-section	5000	2.27	1.176X 10 ⁶	10.93
Aluminum I-section	5000	2.27	0.448X 10 ⁶	3.708
Composite section (G-G-G-C) (90/45/45/90)	5000	2.16	1.309X 10 ⁶	2.408

Table-4:-Review of Axial Stress, axial stiffness & weight Analysis of Steel, Aluminum & optimum composite I- Section beam.

IX. Conclusion :-

For Optimum axial stress of I-section beam can be analyzed by varying stacking sequence & fiber orientation. Carbon Epoxy / Glass Epoxy / Glass Epoxy / Glass Epoxy (90⁰/45⁰/45⁰/90⁰) are less than aluminum & steel I-section beam. The weight of composite beam is reduced up to 78 % than steel & 66 % aluminum. This is intended to ensure for better designing options for composite laminates of I-beam.

X. Future scope:-

The present method can be extended for composite beam with other cross-section such as C-beams & also for un-symmetrical beam .A parametric study can be analyzed for different options like different cross-section ,thickness of layer, lay –up sequence as well as more no. of Layers.

References:

- [1]. W. S. Chan and K.A. Syed, “Determination of Centroid and Shear Center Locations of Composite Box Beams” the University of Texas at Arlington, Texas, USA.
- [2]. Y.X. Zhang, C.H. Yang, “Recent developments in finite element analysis for laminated composite plates”, Composite Structures 88 (2009) .
- [3]. Jun Deng, Marcus, M.K. Lee , Stuart S.J. Moy,“ Stress analysis of steel beams reinforced with a bonded CFRP plate” Composite Structures 65 (2004) 205–215 .
- [4]. Uttam Kumar Chakravarty, “On the modeling of composite beam cross-sections”, Composites: Part B 42 (2011) 982–991
- [5]. İnci Mknz. P. Tum. K. İzgt, Mamak, Ankara, “An Elastic-Plastic Stress Analysis in Silicon Carbide Fiber Reinforced Magnesium Metal Matrix Composite Beam Having Rectangular Cross Section Under Transverse Loading ”, KSME International Journal, Vol 18 No.2, pp. 221- 229, 2004.
- [6]. P.K. Mallick, “Fiber-Reinforced composite Materials”, Third Edition, USA