

## Intelligent Robots For Industries (Using Rf Module)

<sup>1</sup>Alpana Lingayat, <sup>2</sup>Dinesh Rotake

<sup>1,2</sup>Department of Electronics And Telecommunication G H Raison College of Engg. & Tech. for Women  
Nagpur, India

---

**Abstract:** In industry many issues are there, one of them is labour work for transferring goods from one place to another. After a long term of work the labours get tired and their energy to do work is exhausted. Due to this industry faces problems of increasing labour cost as a result increasing overall cost of industry product which is a major issue. To overcome this issues ROBOT can be used for moving goods from one place to another. Robots can work night and day and on holidays also. They can lift weight heavier than human workers. Time required to move goods from one place to another is less as compared to human workers. To increase the movement of goods from one place to another one or more robot can be used. Grids are drawn on the floor of godown so that robot can navigate through godown without any collision through walls and racks (used for storage of goods) .When one or more robots are traversing on the grid, collision may occur .To avoid this collision priority of robots is decided, so that higher priority robot will move through the node while lower priority will wait for the higher priority robot to pass through that node. And finally they will reach their respective destinations.

**Keywords:** RF module, Shortest path ,higher priority, lower priority, collision avoidance.

---

### I. Introduction

In industry many issues are there, one of them is labour work for transferring goods from one place to another. After a long term of work the labours get tired and their energy to do work is exhausted. Due to this industry faces problem of increasing labour cost as a result increases overall cost of industry product which is a major issue.

To overcome this issues ROBOT can be used for moving goods from one place to another. Robots can work night and day and on holidays also. They can lift weight heavier than human workers. Time required to move goods from one place to another is less as compared to human workers. To increase the movement of goods from one place to another one or more robot can be used.

Grids are drawn on the floor of godown so that robot can navigate through godown without any collision through walls and racks (used for storage of goods) .When one or more robots are traversing on the grid, collision may occur .To avoid this collision priority of robots is decided, so that higher priority robot will move through the node while lower priority will wait for the higher priority robot to pass through that node. And finally they will reach their respective destination.

Proposed system has two robots Robot A and Robot B traversing through 4\*4 grids, Robot A will have higher priority than Robot B. Origin of the robots will be same because goods will be loaded and unloaded from the same place, but the destination will be different.

Robots will receive the destination co-ordinates through RF module, so that robot can find shortest distance path to reach the destination co-ordinates.

Robot will pick the object and move towards the respective destination. At a node while traversing Robot A and Robot B comes together to cross the same node on the higher priority bases Robot A will cross the node and Robot B will wait for Robot A to cross that node.

After Robot A cross the node Robot B will traverse through its path to reach its destination. Finally Robot A and Robot B will complete their task by placing goods to their respective destinations.



Figure 1 co-ordinate assigned to the junctions.

## II. Related Work

The line follower Robot is an autonomous machine that follows a predefined path (either black line on white surface or white line on black surface). LED-LDR sensors are installed under the Robot through which Robot senses black or white line and data is transmitted to the processor by processor bus. The microcontroller processes according to the predefined commands, and sends them to the motor drivers [1].

Another study uses 32 phototransistors to instead of the LED LDR sensors. The sensor sends analog signals to the microcontroller and motor drivers work on digital signal. The motor works according to the output of the phototransistor. The phototransistor senses the white line and ground than converts it into electric signal. An AD sampler is used to convert the analog signal to digital signal which is used as an input for the optimization of algorithm [3].

When obstacles are in the path at places known by the Robot, it finds shortest distance path from source to destination using camera by avoiding these obstacles [2].

Traversing in a known obstacle arena is intelligence, whereas traversing in an unknown obstacle arena is a challenge. In micro mouse competition, micro mouse has to reach its destination from the starting point of the maze without manual interference. The main objective of micro mouse is to minimize the cost and to reach its destination in minimum time. The arena has undefined walls/obstacles and the micro mouse has to reach the destination avoiding collision. To avoid unknown obstacles of the path, a new concept of ET-floodfill is used [4].

## III. Proposed System

The aim of our study is to navigate Robot A and B to their destination utilizing less time, less power and shortest possible path taking care that they do not collide with each other.

Our proposed system utilizes, Robot A will have higher priority than Robot B. Starting point for both the Robots will be the same because goods will be loaded from the same place, but their destination can be different.

The RF module will provide destination co-ordinates so that they can find the shortest path to the end point.

Robots will pick the objects and move towards their respective targets, if by chance both of them are about to cross the same node rob A (higher priority) will cross initially followed by rob this will avoid collision

## IV. Basic Structure

Our proposed system utilizes, Robot A will have higher priority than Robot B. Starting point for both the Robots will be the same because goods will be loaded from the same place, but their destination can be different.

The RF module will provide destination co-ordinates so that they can find the shortest path to the end point.

Robots will pick the objects and move towards their respective targets, if by chance both of them are about to cross the same node rob A (higher priority) will cross initially followed by rob this will avoid collision.

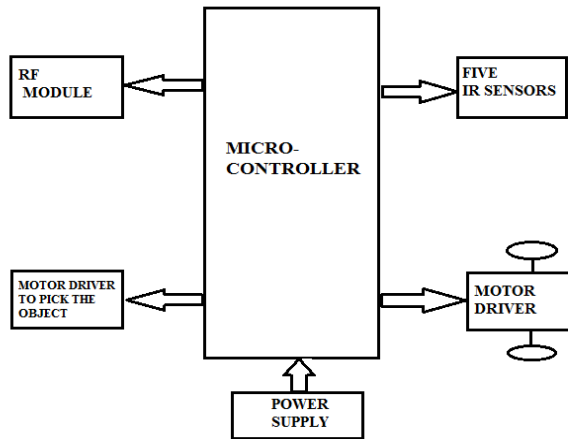

Figure 2 Block diagram of proposed system.

**A. Algorithm**

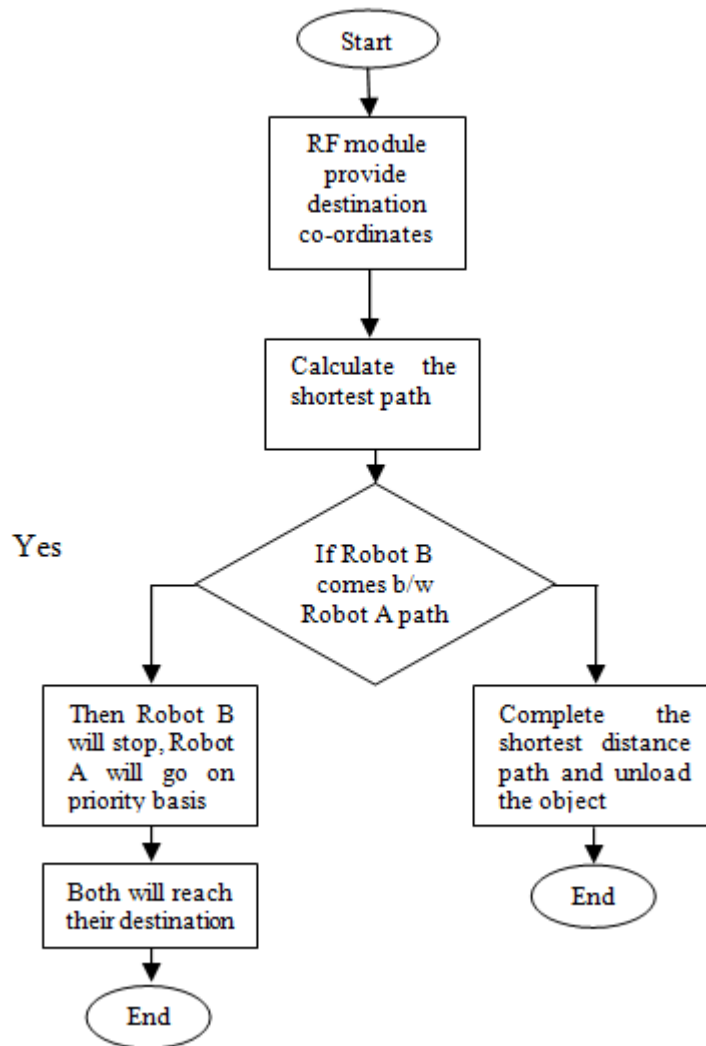

Figure 3 The Flow diagram for robotic path.

### V. Program

```

#include<avr/io.h>
#include<compat/deprecated.h>
#include<util/delay.h>
#define stop PORTC=0b00000000
#define forward PORTC=0b00000101
#define reverse PORTC=0b00001010
#define right PORTC=0b00000001
#define left PORTC=0b00000100
int countx=0, county=0;
int countx1=1;
int county1=0;
char data_rx=0;
char data=0;
unsigned int x=0;y=0;x1=0;
int y1=0;
int j=0;k=0;l=0;
int op=0;op1=0;
{
    UBRRL=baud;
    UCSRB|=(1<<RXEN)|(1<<TXEN);
    UCSRC|=(1<<URSEL)|(1<<UCSZ0)|(1<<UCSZ1);
}
int main(void)
{
    usart_init();
    _delay_ms(1000);
    transmit_char('<');
    transmit_char('1');
    transmit_char('2');
    transmit_char('>');

    flagx=1;
    countx = data_rx-'0';
    countx1 = data_rx-'0';
}
data_rx = receive_data();
if (( data_rx== '1' | '2' | '3' | '4' ))
{
    flagy=1;

    county= data_rx-'0';
    county1= data_rx-'0';
}
while ( flagx==1 && flagy==1 )
{
    if(op==0)
    {

```

**ROBOT A:**

```

sbi(PORTC,5);
cbi(PORTC,4);

if(bit_is_clear(PINB,1)&&bit_is_clear(PINB,2))
forward;
if(bit_is_clear(PINB,1)&&bit_is_set(PINB,2))
right;
if(bit_is_set(PINB,1)&&bit_is_clear(PINB,2))
left;
if(bit_is_clear(PINB,1)&&bit_is_clear(PINB,2) && bit_is_clear(PINB,3) &&
bit_is_clear(PINB,4))
{

```

```

stop;

                                ROBOT B:
                                while(j==0)
                                {
reverse;
j=1;
                                right;
                                while(bit_is_set(PINB,5))
                                {
reverse;
stop;
forward;
}
}
if(bit_is_clear(PINB,1)&&bit_is_clear(PINB,2))
forward;
if(bit_is_clear(PINB,1)&&bit_is_set(PINB,2))
right;
if(bit_is_set(PINB,1)&&bit_is_clear(PINB,2))
left;
if(bit_is_clear(PINB,1)&&bit_is_clear(PINB,2) && bit_is_clear(PINB,3) && bit_is_clear(PINB,4))
{
stop;
y= y+1;
                                forward;
                                while(bit_is_set(PINB,5))
                                {
reverse;
}
}
}
}

```

### VI. Result

Our automatic Robot system for Industries runs on 4\*4 grids, which load goods from the starting point and unload the goods to destination using RF module (manually). After unloading goods the Robots come back to the starting point to load goods. As more than one Robot are used to load/unload goods for transferring goods from one place to another in Industries there is possibility of collision. To avoid collision priority is assigned to them; Robot A has higher priority than Robot B, if Robot B comes in between Robot A's path then Robot B will stop and let Robot A continue its shortest distance path, after cross the junction Robot B will continue its path and both Robots reaches their respective destination.

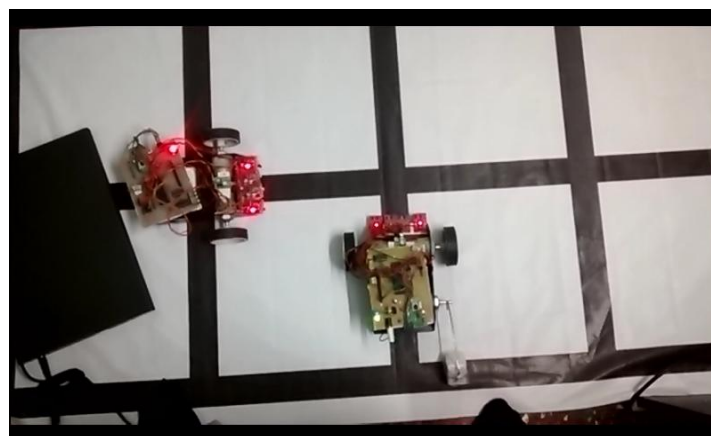

Figure 4 At the starting point Robots will pick the object.

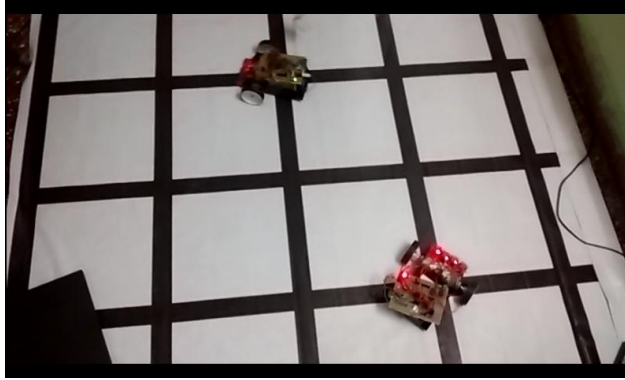

Figure 5 Robots turning to continue their Shortest distance path.

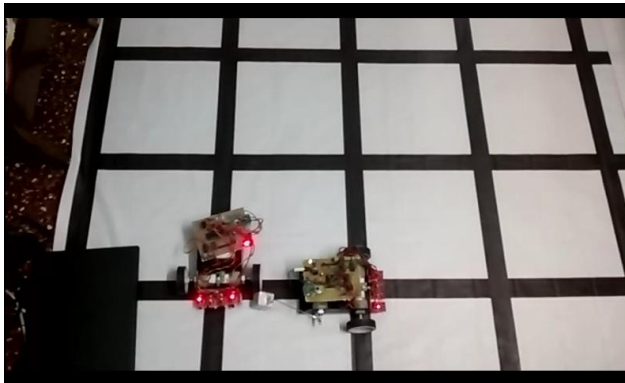

Figure 6 Robot comes back to origin.

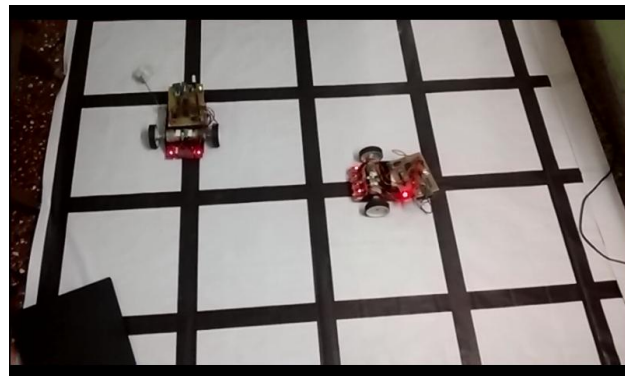

Figure 7 After dropping the object Robot continue its path to come back to starting point.

## VII. Conclusion

Our Robot system using RF module is a fairly accurate means of transporting goods. Robot reduces manual work in Industry for moving goods from one place to another. As Labour cannot work 24\*7 (on holidays) due to which Industry has to invest more on Labour payment due to which overall product cost increases.

Robots can overcome this issue as they can work continuously without break and 24\*7 due to which labour payment is decreased which is beneficial for the Industry. Robots can move goods heavier than the labours due to which more goods are transferred from one place to another.

Thus with the above advantages and hardly any short coming, the system has bright prospect for application in industries.

**References**

- [1] Ankita Saxena, Abhinav Saxena “A new generation grid solver Robot system for object picking using shortest path” 2012 IEEE.
- [2] Atul Patel, Anupam Dubey, Ajitesh Pandey, Siddharth Dutt Choubey “Vision Guided Shortest Path Estimation Using Flood fill Algorithm for Mobile Robot Applications” 2012 IEEE.
- [3] Yichao Li, Xiaoling Wu, Dongik Shin, Weijun Wang, Jianing Bai, Qing He, Fei Luo, Weimin Zheng “An Improved Line Following Optimization Algorithm for Mobile Robot”.
- [4] Zhuang Cai, Lu Ye, Ang Yang “Flood fill maze solving with expected toll of penetrating unknown walls for micro mouse” 2012 IEEE.
- [5] Brooks, R.A., “A robust layered control system for a mobile robot”, IEEE Journal of Robotics and Automation, vol. 2, no. 1, (1986): 14-23.
- [6] Thirumurugan. J, Kartheeswaran. G, Vinoth. M, Vishwanathan. M, “Line following robot for library inventory management system”, International Conference on Emerging Trends in Robotics and Communication Technologies (INTERACT), pp.3-5, Dec 2010.
- [7] Jae Sung and Byung Kook Kim, "Minimum-Time Grid Coverage Trajectory Planning Algorithm for Mobile Robots with Battery Voltage Constraints", International Conference on Control, Automation and Systems, 2010