

Design of Intelligent Autonomous Wheeled Robot Using Rf Transmission

P. Radhika,
ME, Assistant Professor / MCT,
Akshay Venkat, *BE MCT,* Gowtham. G, *BE MCT.*
P. Athul, *BE MCT,*

Abstract: *Embedded system is an emerging field with immense applications in Science and Engineering. The designed ROBOT is a portable machine. Communication between ROBOT and the Control Unit is performed through Radio Frequency (RF) Communication. The system basically has two modes. The automatic mode is the first mode and the user control mode is the second mode. ROBOT is controlled with the help of Microcontroller in the control unit and is programmed my means of microcontroller in it. The primary aim of the project is to design, develop and implement Automatic Wall Painting Robot which helps to achieve low cost painting equipment along with object recognition. The robotic system is remote controlled. Thus the aim is to provide a robotic system that can be used in industrial applications. In this paper the robot is controlled from the system using MATLAB software*

I. Introduction

Embedded systems are controlled by one or more processing cores that are either microcontrollers or digital signal processors (DSP). Hence, the robot is designed using the concept of embedded systems. Embedded Systems are mostly Processor and controller based like General Processors, Micro Processors, DSP and Microcontroller. In this paper, the S8951 Micro controller is used for controlling the robot[1][2].

Industrial automation and robotics are at a high demand in the industry as both of them directly affect the growth of the industry. Autonomous robots with sensors used in industries directly results in the growth of the industry. When construction workers and robots are properly integrated in industries, the whole construction process can be better managed and savings in human labour and timing can be obtained as a consequence. Colour is the most common feature to distinguish between objects for sorting, recognizing and tracking.

The robot in this paper is used for general tasks such as painting and object recognition with high precision and accuracy. Robot is mounted with a camera in its workspace to detect the object and also to telecast the video for live transmission of video signals in the control unit PC. The robot works based on the sensory information and programmed in Image processing toolbox in MATLAB. The robot can be used in material handling in logistics and packaging industry where the objects moving through a conveyer belt can be separated using a colour detecting robot.

Radio Frequency (RF) transmission uses radio waves like radio or television signals to transmit audio and video signals via a carrier from a transmitter to a receiver. Radio frequency (RF) is a rate of oscillation in the range of about 30 kHz to 300 GHz, which corresponds to the frequency of electrical signals used to produce and detect radio waves. The transmitter has an antenna attached to the transmitter unit which needs to be positioned to cover the listening area. The receiver unit is either single channel or multichannel and it receives the modulated radio waves and convert them back into an audio signal which is sent to the headphone output[3][4].

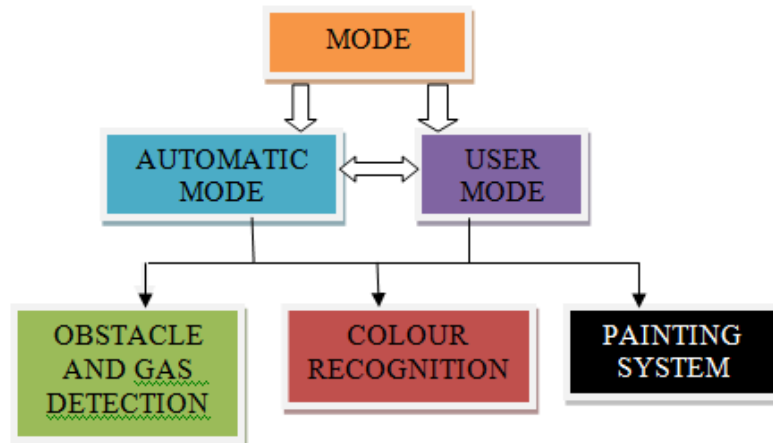

Figure 1: Process Diagram

Characteristics of Robotics

Robots can be in various forms like Manipulator, humanoid robot, Legged robot, wheeled robot, Autonomous underwater robot, unmanned aerial robot. The robot performs jobs that are dangerous, boring, stressful or labour-intensive for humans. The characteristics of a robot can be programmed through softwares like MATLAB, Visual Basic, Lab VIEW, C, etc.,

Need For Robots

Often, robots are used to do jobs that could be done by humans but there are many reasons why robots are better than humans in performing certain tasks.

Speed: Robot may be used because they are FASTER than people at carrying out tasks as it is a mechanism which is controlled by a computer. Some robots actually MOVE more quickly than we can, so they can carry out a task such as picking up and inserting items, more quickly.

Hazardous (Dangerous Environments): Robots may be used in places where a human would be in danger. For example, robots can be designed to withstand greater amounts of Heat, Radiation, Chemical fumes, than humans could.

Repetitive Tasks: Sometimes robots are not really much faster than humans, but they are good at simply doing the same job over and over again. This is easy for a robot, because once the robot has been programmed to do a job the same program can be run many times to carry out a job many times. And the robot will not get bored as a human would.

Efficiency: Efficiency is all about carrying tasks without waste. This could mean not wasting time, not wasting materials, not wasting energy.

Accuracy: Accuracy is about carrying out tasks very precisely. When items are being assembled, a robot can position parts within fractions of millimeter

A Robot Has Four Essential Characteristics:

Sensing: First of all, Robot would have to be able to sense its surroundings. A robot needs to move around its environment either rolling on wheels, walking on legs.

Energy: A robot needs to power itself. A robot might be solar powered, electrically powered, battery powered.

Intelligence: A robot needs some kind of "smarts" where it is programmed.

Adaptability: Adaptability is where a robot can be used to carry out more than one task. The program which controls the robot can be changed. An adaptability robot is developed and designed in this paper

Laws Of Robotics

Asimov proposed three “Laws of Robotics”

Law 1: A robot may not injure a human being or through inaction, allow a human being to come to harm.

Law 2: A robot must obey orders given to it by human beings, except where such orders would conflict with a higher order law.

Law 3: A robot must protect its own existence as long as such protection does not conflict with a higher order law.

II. Existing Work

Labours in the construction industry are not sufficient because of the difficulty in work, improvement in the education level makes people to think that these types of work is not as prestigious as the other jobs. In construction industry, during the work in tall buildings the risky situation is more. The nature of painting and object recognition procedure requires repeated work and hand rising makes it boring, time and effort consuming. The painting chemicals can cause hazards to the human painters in eye and respiratory system.

III. Proposed Work

In addition to manual mode, the system has automatic mode in which the robot can take its own decision. Applications of robotics and automation in construction industries improve safety and ensures quality environment. In order to reduce the number of labours, automation in painting was introduced in this paper. Features like object recognition, gas detection is also included. Thus our system is more reliable to be used in industries than the existing manual method of object detection in pick and place application and painting. The system contains object and color recognition module which is carried out using vision system techniques.

IV. Construction And System Model

The robot model contains a 3 axis robot arm with three servomotors for painting and color identification. It is a type of programmable mechanical arm, similar to a human arm. The links of the robot manipulator are connected by joints allowing either rotational motion or translational displacement. The robot arm consists of three DC motors one for the base, one in the middle and another for the gripper to pick and drop the objects detected. Two servomotors are used for movement. The two wheels of the robotic vehicle are connected to the DC motors which are in turn connected to the microcontroller. The microcontroller through the incoming signal controls the movements of the robot while performing painting operation and object recognition operation. The microcontroller used is 89S51. RS232 communication was used for MATLAB to communicate with the microcontroller.

V. Object Recognition

In the object recognition mode, the robot can identify the object through the microcontroller and sends the signal to the control unit using RF transmitter for driving the motor to pick and place the object. In the control unit, the object can be sorted along with colour recognition using the MATLAB algorithm in the PC and send command to the controller using serial communication. The robot detects the object using vision system. Other features such as orientation, gradient magnitude can also be added. In this paper the detection of different colours is done through image processing technique using MATLAB. For object recognition MATLAB has the most powerful tool box for image improving, enhancing and categorizing using features such as colour, dimensions and texture of the object. Wavelet transforms in the PC decomposes the image into a group of pixels. The robot model is used to pick and place the desired colour objects from one location to another with actions like gripper open, gripper close, left and right movement on the robot. This robot sorts the objects in a mixture of different coloured objects from the conveyor belt [7].

VI. Painting System

The construction of the automatic wall painting robot consists of two main parts. They are Mobile platform and spray gun mount. The mobile platform consists of Frame stand, IR sensor, Solenoid valve, Sprocket, Flow control valve and Spray gun and the spray condition determining unit at the control unit. The frame stand is the steel welded to carry the spray gun. The movement of the frame stand is controlled by the DC motor rotation which is controlled by the microcontroller. The robot is simple and portable. The system operates in pneumatics and it needs air tank or compressor [8].

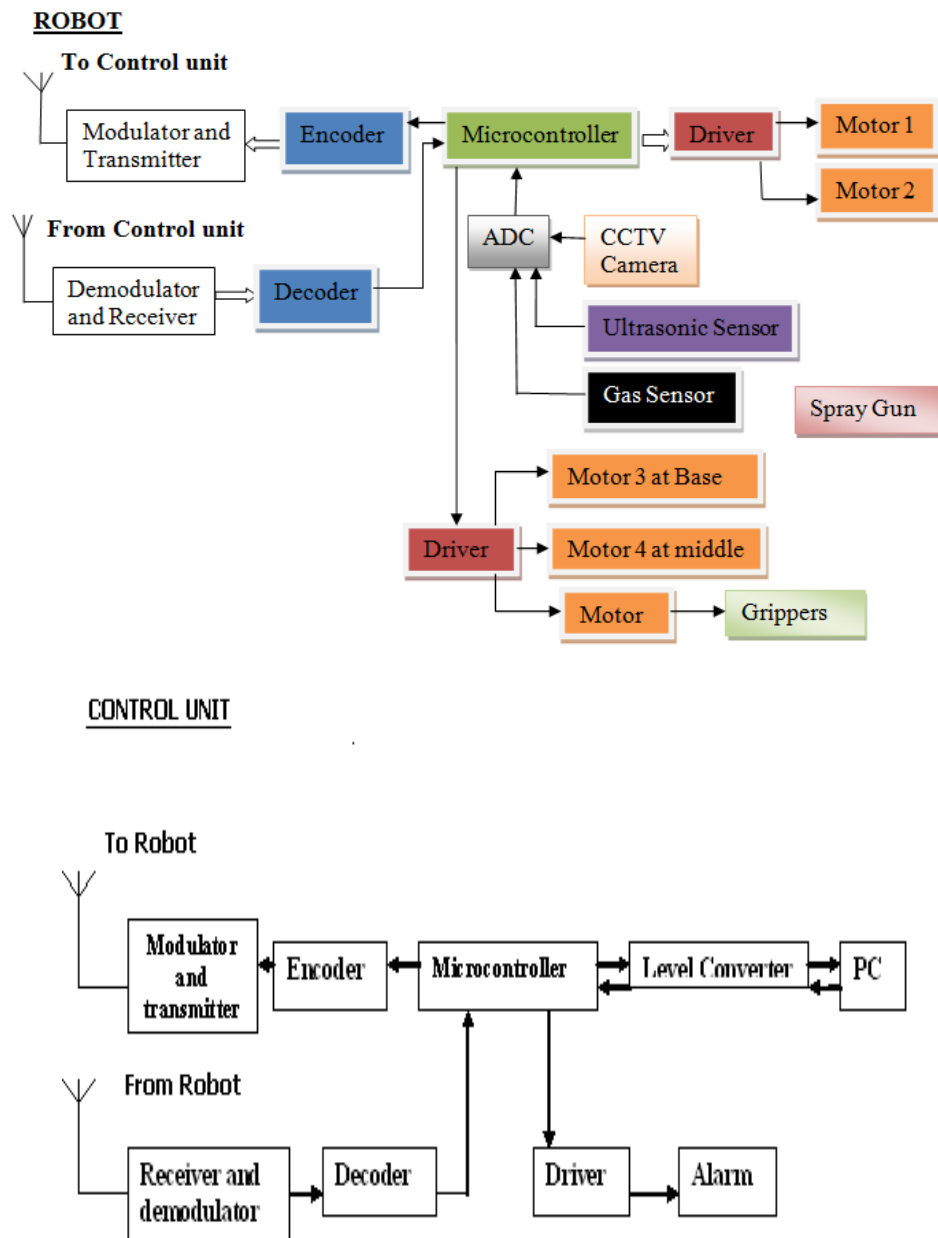

Figure 2: System Model

VII. Software Development

The actions performed by the robot are written as coding in 89S51 microcontroller using embedded C language. The following steps are involved in the software development: Coding/debugging, Compiling and Burning

VIII. Working Principle

Initially the two motors connected with the wheels will be powered by the battery and the robot starts to move by capturing video in the automatic mode. It estimates an obstacle in its path and changes its direction accordingly. The robot can be changed to user mode for applications like painting and object recognition. When robot visualizes an object, the signal will be sent to the microcontroller in the robot. The signal will be sent from the RF transmitter to the microcontroller RF receiver. The image acquisition tool box in MATLAB software calculates the number of pixels in the image for identifying the colour of the object. Once the colour is determined the object can be sorted through the gripper motor after the command signal from the Microcontroller in the control unit[9].

IX. Hardware Requirements

Automatic Mode and User Mode

In automatic mode the user has no control over the robot. The robot takes it own decisions and performs the required operation using Artificial Intelligence. At unavoidable circumstances the control automatically goes to the user mode. In user mode, the user has the full control of the robot from remote location and performs the required operation.

Microcontroller

Microcontroller is a microprocessor with memory unit. The Microcontrollers used in the Main Station and the Robot is ATMEL 89S51. Micro controller can control external signals from Robot, Control Unit.

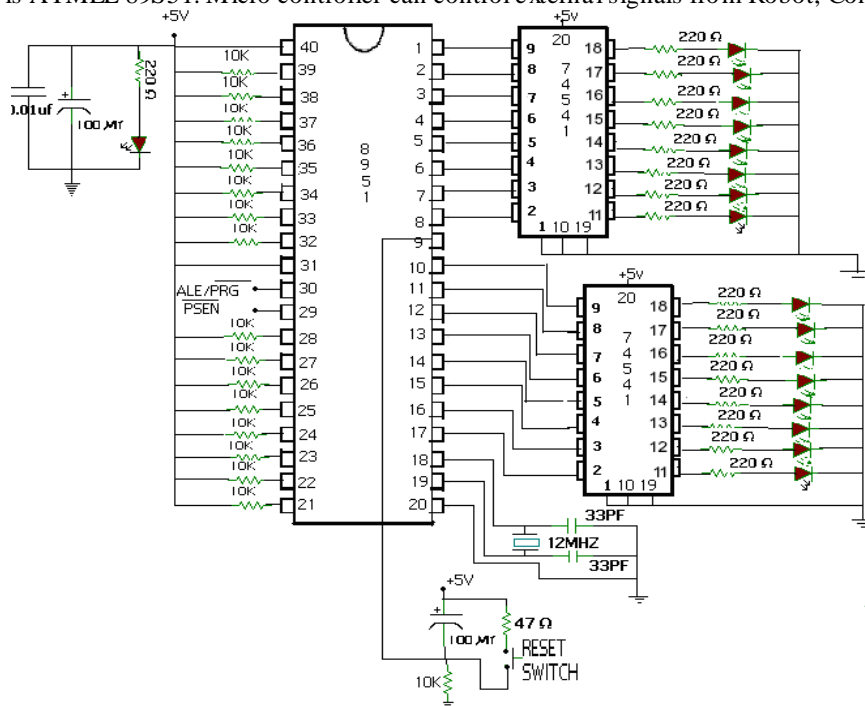

Figure 3 : Microcontroller 89s51

Gas Sensor

A gas sensor detects the presence of combustibile, toxic oxygen and CO₂ gases within an area to warn about gases which might be harmful to humans or animals. The dimensions of the gas sensor is 18mm in Diameter, 17mm High excluding pins, Pins - 6mm high. The response time of the gas sensor in the robot is less than 10s. Cryogenics such as liquid nitrogen (LN₂), helium (He) and argon (Ar) can inert or deplete oxygen (O₂) in a confined space if a leak is present. A rapid decrease of oxygen can provide a very dangerous environment for employees in the industries, so the designed robot also determines the depletion in oxygen and the presence of a dangerous gas leakage in hazardous environment. The sensor can also sense iso-butane, propane, LNG and cigarette smoke [5][6].

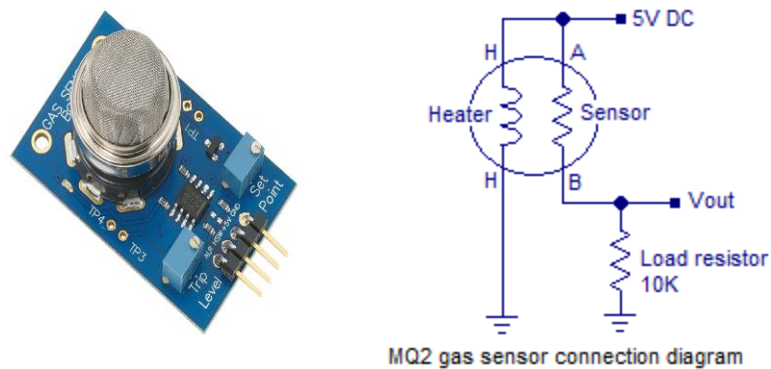

Figure 4: Gas Sensor

Ultrasonic Sensors

The ultrasonic sensor makes use of ultrasonic waves to sense the presence of an obstacle in its path and deviates its path or stops its journey. The sensor is connected to the pins of the microcontroller and takes any action depending upon the feedback received from the ultrasonic sensor. The circuit consists of ultrasonic transmitter and receiver both are similar to LED. Its operating voltage is around 1.4V. The transmitter continuously transmits the ultrasonic rays. At the output pin, voltage is approximately 5v. Here the micro controller part is to control the movement of the robot as well as to read the input from the sensor unit. The robot consists of 2 dc motors to rotate the wheels of the robot. The motor is rotated as per the direction in which the robot should move in the automatic mode or as per the instruction from the user in user mode.

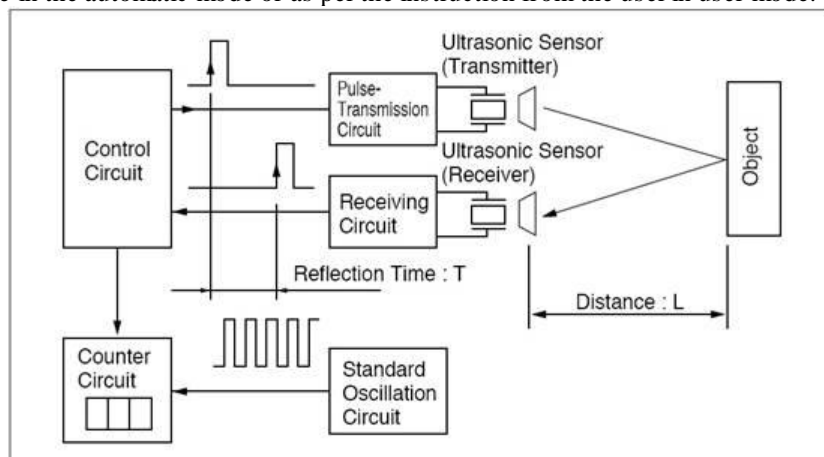

Figure 5: Ultrasonic Sensor

Dc Motor

Servomotors are also called as DC motors with built in gearing system and feedback loop control circuitry. When the shaft of the motor is at the desired position, power supplied to the motor is stopped. If not, the motor is turned in the appropriate direction. The desired position is sent by electrical pulses through the

signal wire. The motor's speed is proportional to the difference between its actual position and desired position. If the motor is near the desired position, it will turn slowly, otherwise it will turn fast. This is called proportional control. Servo motors have rotary actuators that allow precise angular position [10].



Figure 6 :Dc Motor

DC Motor Driver

The DC motors of the robot are connected to the controller using a motor driver IC. As the output of the controller is maximum 5v, it cannot drive the motors. So, to amplify this voltage motor driver, IC is used. L293D can amplify up to 36v. The driver IC has 16 pins. 2, 7, 10, 15 are input pins and are connected to the PD0-PD3 pins of microcontroller. 16 pin is connected to 12v. This voltage drives the motors. 8th pin is connected to 5v for internal operations of the IC[9].

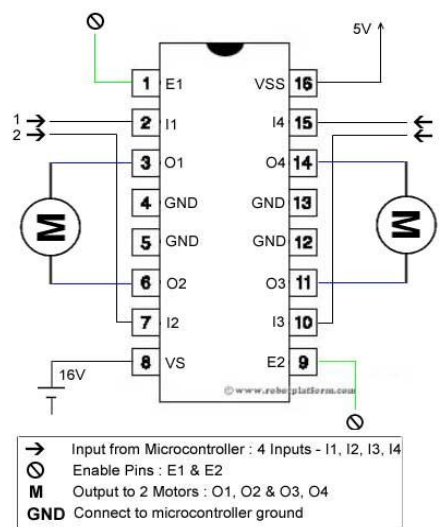

Figure 7 :Dc Motor Driver

Video Transmission

In this paper, live video transmission is carried out by video capturing device -wireless camera in the robot and with video perception device- TV tuner in the control unit. The CCTV camera can be equipped to capture images and then transmit them to a central device. With the help of camera real time image of an object can be sent to PC with MATLAB software.

Image Processing

Pixel is the building blocks of an image. A Binary image consists of black and white pixels. Grey scale Image contains intensity values ranging from a minimum (absolute black) to a maximum (absolute white) and in between varying shades of grey. Typically, the range is between 0 and 255. For a binary image, the value of each element in the matrix is either 0 or 1 and for a grey scale image each value lies between 0 and 255. Colour image is composed of the three primary colours like Red, Green and Blue. Hence it is called as RGB image. A colour image is stored as an $m \times n \times 3$ matrix where each element is the RGB value of that particular pixel.

Encoder

The 2^{12} encoders are a series of CMOS LSIs for remote control system applications. They are capable of encoding information, which consists of N address bits and 12^N data bits. The encoders begin a 4-word transmission cycle upon receipt of a transmission enable (TE). This cycle will repeat itself as long as the transmission enable (TE) is held low.

Decoder

The 2^{12} decoders are a series of CMOS LSIs for remote control system applications. They are paired with 2^{12} series of encoders. For proper operation, a pair of encoder/decoder with the same number of addresses and data format should be chosen. The decoders receive serial addresses and data from a programmed 2^{12} series of encoders that are transmitted by a carrier using an RF transmission medium. They compare the serial input data three times continuously with their local addresses. If no error or unmatched codes are found, the input data codes are decoded and then transferred to the output pins.

The 2^{12} series of decoders provides various combinations of addresses and data pins in different packages to pair with the 2^{12} series of encoders. The decoders receive data that are transmitted by an encoder. A signal on the DIN pin activates the oscillator, which in turn decodes the incoming address and data. The decoders will then check the received address three times continuously. If the received address codes matches with the contents of the decoder's local address, the 12^N bits of data are decoded to activate the output pins and the VT pin is set high to indicate a valid transmission. This will last unless the address code is incorrect or no signal is received. The output of the VT pin is high only when the transmission is valid. Otherwise, it is always low[9].

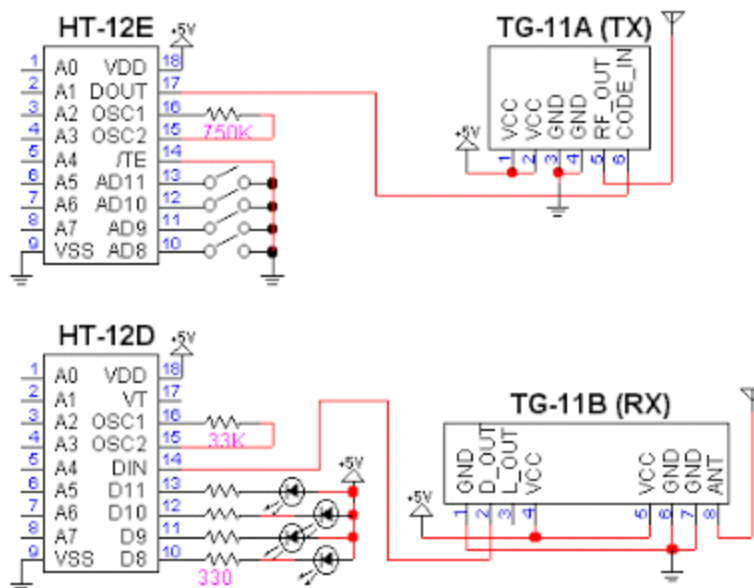

Figure 8 :Encoder And Decoder

Analog To Digital Converter

ADC 0809 analog to digital converter is a successive approximation type Analog to Digital Converter. The ADC0809 data acquisition component is a monolithic CMOS device with an 8-bit analog-to-digital converter, 8-channel multiplexer and microprocessor compatible control logic [10].

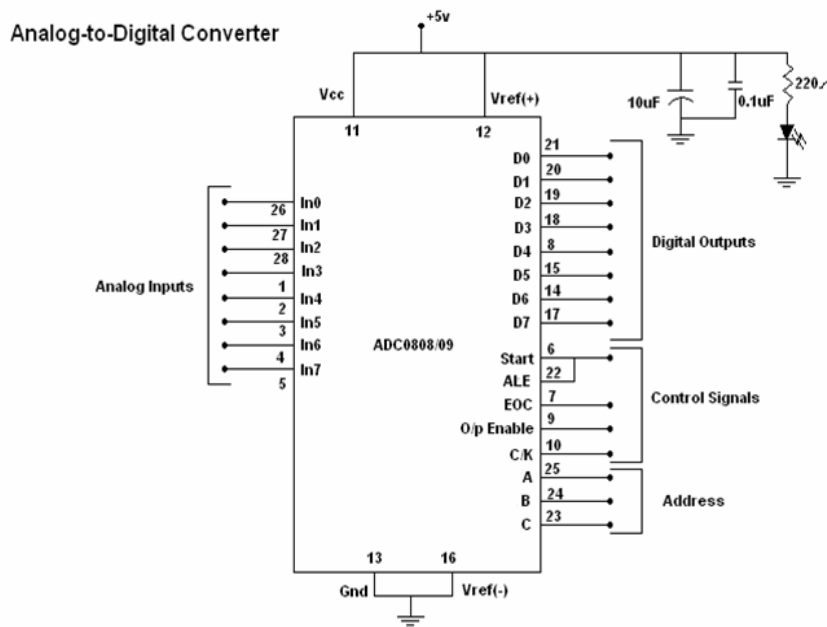

FIGURE 9: Circuit Diagram of Analog to Digital Converter

Level Converter

When PC communicates with microcontrollers the RS232 levels should be converted down to lower levels, typically 3.3 or 5.0 Volts. Serial RS-232 (V.24) communication works with voltages -15V to +15V for high and low. On the other hand, TTL logic in the microcontroller operates between 0V and +5V. Modern low power consumption logic operates in the range of 0V and +3.3V or even lower. Thus the RS-232 signal levels are far too high TTL electronics, and the negative RS-232 voltage for high can't be handled at all by computer logic. To receive serial data from an RS-232 interface the voltage has to be reduced. Also the low and high voltage level has to be inverted. This level converter uses a Max232 and five capacitors. The max232 is quite cheap. The MAX232 from Maxim was the first IC which contains drivers and receivers to adapt the RS-232 signal voltage levels to TTL logic [11].

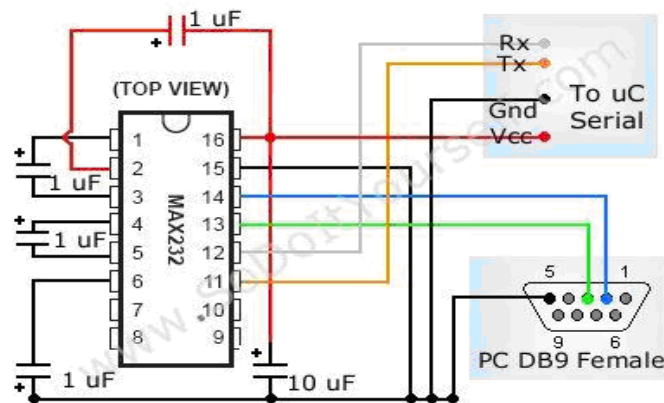

Fig 10: Circuit diagram of Level Converter

Rf Transmission

Radio Frequency (RF) transmission uses radio signals to transmit audio by a carrier from a transmitter to a receiver. Like a radio station transmitter, the transmitter has an antenna attached to the transmitter unit which needs to be positioned to adequately cover the listening area [4]. The receiver units are either single channel or multi channel and they receive the modulated radio waves and convert them back into an audio signal. Multichannel receivers will have a channel selector which allows a user to select a specific transmission channel. Since the antenna may pick up thousands of radio signals at a time, a radio tuner is necessary to tune in to a particular frequency (or frequency range). This is done by a resonator with a capacitor and an inductor

forming a tuned circuit. The resonator amplifies oscillations within a particular frequency band. Often the inductor or the capacitor of the tuned circuit is adjustable and allows the user to change the frequencies at which it resonates [3].

1) RF Transmitter:

The TWS-434 transmitter is used for short-range RF remote controls. The TWS-434 transmitter is placed inside a small plastic enclosure. The transmitter is given a power supply of 5V. The output power of the transmitter is up to 8mW at 433.92 MHz. The coverage area of the transmitter will be 400 foot in open area or in the outdoors and in indoor the coverage area will be about 200 foot. The TWS-434 transmitter accepts both linear and digital inputs can operate from 1.5 to 12 Volts-DC. The input is given to the pin-2. The power supply is provided in the pin-3. The RF output is produced in the pin-4, where the antenna is connected.

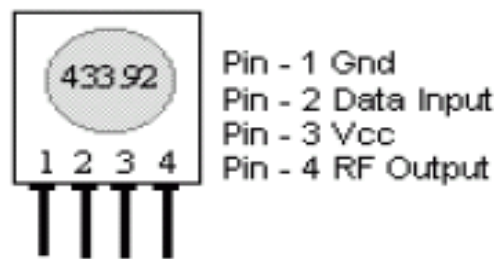

Fig 11: Transmitter Section

The transmitter transmits 4 words for each transmission of the signal. The 4 bit data from the pin 17 of the encoder moves to the data input pin of the transmitter and from there the data is transmitted through the antenna. The voltage consumed by the transmitter will be about 2.85v in the encoder. The carrier frequency is 433MHZ [3][4].

2) RF Receiver

The receiver RWS 434 also operates at 433 MHz. The receiver has a sensitivity of 3µA. It operates at 4.5V to 5.5V. The output produced by receiver can be either linear or digital. The distance between the pin1 and pin 8 is 43.5mm. The distance between the pin4 and pin5 is 25.4mm. The digital output will reach the decoder from the pin2 and the linear output will be present in the pin 3. The receiver RWS 434 section is used along with the HT-12D decoder IC for a 4-bit RF remote control system. For maximum range, the antenna size can be increased from 30-35cm [3][4].

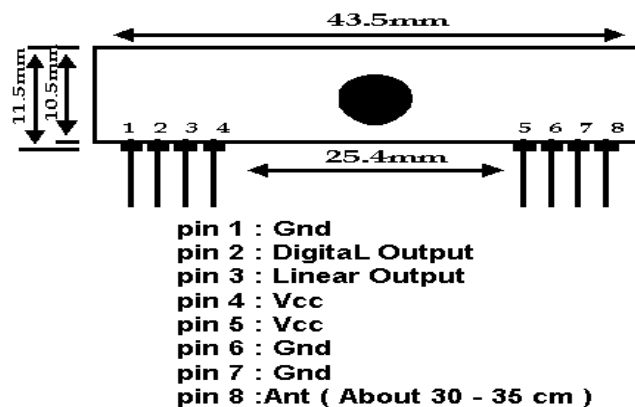

Fig 12: Receiver Section

Advantages

- ✓ Less noise vibration
- ✓ It has longer life
- ✓ low cost and highly efficient
- ✓ Ruggedness with longer life
- ✓ Simplicity in construction
- ✓ High reliability with flexibility
- ✓ No maintenance and Wide acceptance

- ✓ Installation is simple
- ✓ No feedback components are needed
- ✓ The rotation angle of motor is proportional to input pulse.
- ✓ The motor has full torque at standstill
- ✓ Precise positioning and repeatability of movement since good stepper motors have an accuracy of 3-5% of a step and this error is non-cumulative from one step to next.
- ✓ Excellent response to starting, stopping, reversing.

X. Future Enhancements

The color detection capacity of the robot can be increased to blue and green along with red which can sort out wide range of objects. The robot can be enhanced with pattern recognition and Speech recognition features which plays a vital role in many industries and also increases the accuracy of the task in logistic and packaging industry.

XI. Conclusion

The developed ROBOT detects the presence and colour of the object and place it in the desired location. The robot is controlled through wireless communication in industries with hazardous environment. The objective is met by sorting the objects based on the color from a group of objects which can be monitored through live video transmission. Thus an automatic painting robotic system can be developed along with the capability of detecting gas leakage in the working environment.

References

- [1]. C.Alippi: Intelligence for Embedded Systems. Springer, 2014, 283pp, ISBN 978-3-319-05278-6.
- [2]. Heath, Steve (2003). Embedded systems design. EDN series for design engineers (2 ed.). Newnes. p. 2. ISBN 978-0-7506-5546-0. An embedded system is a microprocessor based system that is built to control a function or a range of functions
- [3]. Jeffrey S. Beasley; Gary M. Miller (2008). Modern Electronic Communication (9th ed.). pp. 4–5. ISBN 978-0132251136.
- [4]. Jump up "Definition of RADIO FREQUENCY". Merriam-Webster. Encyclopedia Britannica. n.d. Retrieved 6 August 2015.
- [5]. Kneip, L., F.Tache, *et al.*, 2009. Characterization of the compact Hokyo URG-04LX 2D laser range scanner Proc. of IEEE Int. Conf. on Robotics and Automation, pp: 1447-1454.
- [6]. ROBOTICS, Control, Sensing, Vision and Intelligence - K.S.Fu, R.C.Gonzalez, C.S.G.Lee
- [7]. PRINCIPLES OF ROBOT MOTION, Theory, Algorithm, Implementation -Choset, Lynch, Hutchinson, Kantor, Burgard, Kavraki and Thrun FUNDAMENTALS OF ROBOTICS Analysis and Control – Robert J.Schilling
- [8]. S.C.Jacobsen, et al.(1986) "Design of the Utah/MIT Dexterous Hand," Proc. IEEE Inter Conf. on Robotics and Automation, pp 1520-1532.
- [9]. Yoky Matsuoka(1997) "The Mechanism in a Humanoid Robot Hand", Autonomous Robots, Vol.4, No. 2, pp.1999- 2009.
- [10]. C. S. Lovchic and M. A. Diftler: The Robonaut Hand(1999) "A Dexterous Robot Hand for Space", Proc. of the 1999 IEEE International Conference on Robotics and Automation, pp. 907-912.