

Optimum Location of EDFA based on Eye Diagram, Q-factor and Bit Error Rate Metrics

Nabil Elsheikh Mohamed Elmak ¹, Dr. Amin Babiker A/Nabi Mustafa ²
^{1,2}(Telecommunications Engineering, Faculty of Engineering/ Neelain University, Sudan)

Abstract: This work investigated the optimum location of Erbium Doped Fiber Amplifier (EDFA) in an optical system based on analysis of BER analyzer metrics by simulation approach using Optisystem software. The simulation model will be studied based on many parameters as input power (dBm), gain of Amplifier (dBm), fiber cable length (km) and attenuation coefficient (dB/km), there are two different parameters will be analyzed at five different locations of EDFA which are Q-Factor and Bit Error Rate (BER) and also Eye Diagram, which Q-factor and BER are measurement parameters used to measure the quality of received signal at receiver.

Keywords: EDFA, Bit Error Rate, Optical Amplifier, Optisystem simulator, Optical System, Q-factor

I. Introduction

Optical fiber systems are the most trustworthy telecommunication technologies based on the principle that light can carry more information over longer distances in a glass medium to achieve consumers' needs for current and upcoming applications [3]. When the signal travels in an optical fiber it suffers from various losses like fiber cable attenuation losses and fiber splice losses [2]. Due to these losses, it is difficult to detect the signal at the receiver side. So to transmit a signal over a long distance in a fiber (more than 150km), it is required to compensate the losses in the optical fiber. For compensating the losses, an optical amplifier is needed. Optical Amplifier as EDFA can diminish the effects of attenuation to enhance the performance of optical systems when the signal travels in long distances [1].

Erbium-doped fiber amplifier (EDFA) is an essential part in the long-haul optical fiber communication systems. Propagation losses are the biggest concern for optical fibers. But usage of EDFA has helped immensely in compensating losses during signal propagation. EDFA works better in the range 1530 to 1565 nm with Gain up to 30 dBm. EDFA consists of a length of Erbium doped fiber, Laser diode used as pump and wavelength selective coupler to multiplex or combine the signal and pump wavelength together so that they can transmit at the same time in the fiber. EDFA works on the principle of stimulated emission and pumps laser is used to provide energy and excite ions to an upper energy level [4]. This paper discusses in a few words the best location of EDFA based on performance metrics in optical transmission system at different five locations using simulation software (Optisystem v7.0). Optisystem is a simulation software for simulating optical fiber systems. Optisystem allows users to design and simulate optical systems. This software has many analyses tools such as BER analyzer, spectrum analyzer, signal power meter, and etc. The BER analyzer is used to find the BER and the Q-factor of the signal in the optical system [5].

II. Methodology

In analyzing and designing optical networks there are several methods can be used. For this study simulation approach is used. Optisystem software v7.0 was selected to be used in designing an optical system using EDFA in different locations. Each system was simulated by the same set of design parameters and each system consists of Transmitter, Optical Amplifier (EDFA), Optical Fiber Cable, Receiver (Photo Detector and LPF), Power Meters and BER Analyzer, as shown below in Fig. (1).

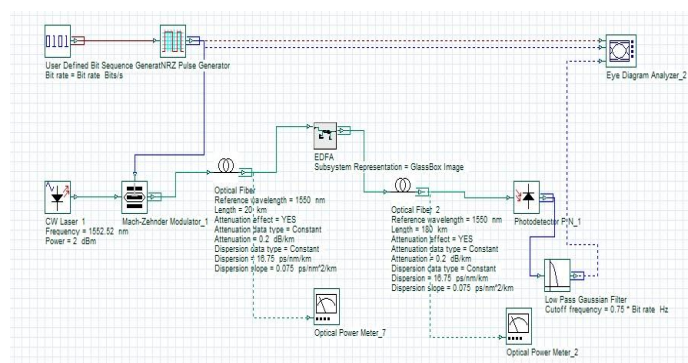

Fig. 1 Optical System Model using EDFA

The design parameters consist of a length of Optical Fiber Cable (km), Bitrate (bit/s), Transmit Power (dBm), Gain of Amplifier (dBm) and Loss of Cable (dB/km) and Frequency (nm) for each optical system model shown in Table (1).

Table 1 The Design Parameters

Description	Values	Unit
Optical fiber length	200	Km
Bit rate	622	Mb/s
Transmit Power	-0.44	dBm
Gain of Amplifier	20	dBm
Frequency	1550	Nm
Loss of Cable	0.2	dB/km

In the simulation, the design model has been repeated by changing the location of EDFA in each time (20 km, 60km, 100km, 140km, and 180km) from the transmitter as shown in Fig. (2), in each location, the flowing parameters has been analyzed: Bit Error Rate, Q-factor and Eye Diagram.

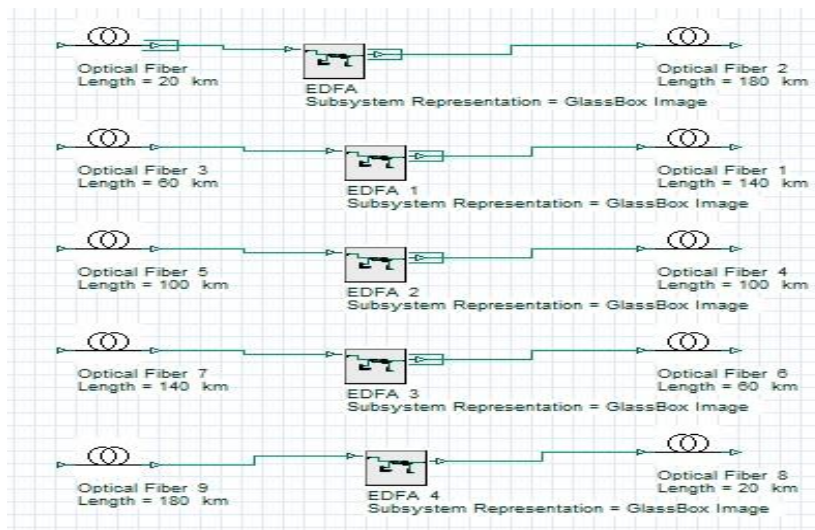

Fig. 2 Different locations of EDFA

III. Results and Discussion

Q-factor and Bit Error Rate has been examined throughout the simulation at different locations of EDFA from the transmitter as shown in Table (2). The Eye Diagram graphs are also plotted as shown in Fig (3), Fig (4), Fig (5), Fig (6) and Fig (7) for each location of EDFA from the transmitter.

Table 2 The Examined Parameters

Description	At 20 km	At 60 km	At 100 km	At 140 km	At 180 km	Unit
Q-Factor	14.4548	26.9345	29.4625	26.1712	21.8828	percentage
Bit Error Rate	1.1592e-047	4.3098e-160	4.3149e-191	2.8252e-151	1.8839e-106	percentage

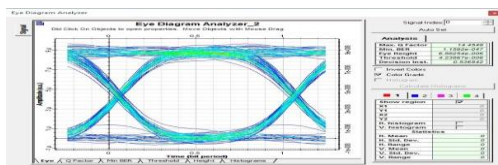

Fig.3 Eye Diagram graph using EDFA at 20 km

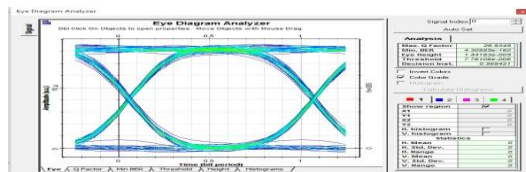

Fig. 4 Eye Diagram graph using EDFA at 20 km

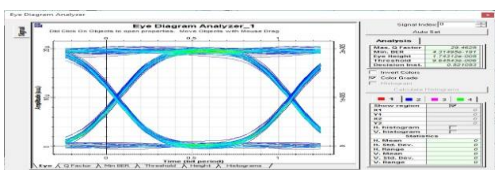

Fig.5 Eye Diagram graph using EDFA at 100 km

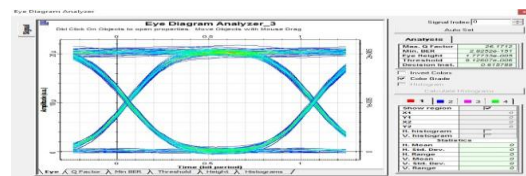

Fig. 6 Eye Diagram graph using EDFA at 140 km

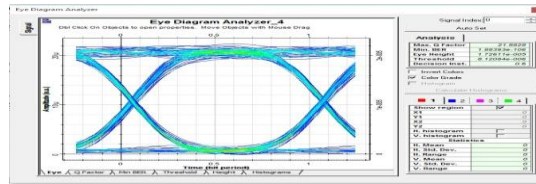

Fig.7 Eye Diagram graph using EDFA at 180

From the simulation results as shown in Table (2), it shows Q-factor and BER readings which obtained by using EDFA at five different locations from the transmitter in optical system model, in this model when EDFA at 100 km from the sender the Q-factor is highest and the BER is the lowest, also when the EDFA is closed to the transmitter or the receiver the Q-factor and BER got the worst values. From Figure (5) when EDFA at 100 km shows the largest eye diagram opened while the EDFA at 20 km shows the smallest eye diagram opened. From the results of BER analyzer and Eye Diagram of EDFA at different locations, it is obvious when EDFA is used closed to the transmitter or the receiver affect the performance of the optical system. So it better to locate EDFA far from transmitter and receiver, in this case, the distance between two nodes is 200 km, the optimum location of EDFA is 100 km from the transmitter.

IV. Conclusion

Optical amplifiers achieve a major role optical communication systems, allow transmitting high data rates over distances up to thousands of kilometers. In this work, the simulation tool is used (Optisystem v7.0), to study optical transmission networks using EDFA at different locations in optical line between transmitter and receiver. From the simulation results, it can conclude that in the case of using EDFA at 100 km from transmitter Out of all possible locations considered in this work, performs better with lowest BER and highest open eye diagram. From this analysis, EDFA can be implemented and is recommended to use in long-haul optical systems.

References

- [1] Fiber-Optics.info, Optical Amplifiers, http://www.fiber-optics.info/articles/optical_amplifiers.
- [2] Warsha Balani and Manish Saxena, EDFA Gain Performance analysis at 2Gbits/sec in Optical Transmission System, *International Journal of Multidisciplinary and Current Research*, August 2013, ISSN: 2321-3124.
- [3] Gridhar Kumar R, Iman Sadhu and Sangeetha N, Gain and Noise Figure Analysis of Erbium Doped Fiber Amplifier by Four Stage Enhancement and Analysis, *International Journal of Scientific and Research Publications*, Volume 4, April 2014, ISSN 2250-3153.
- [4] Varsha Honde, Anuja Mhatre, Sourabh Tonde, Supriya Barkul and Pruthviraj Pund, Performance Analysis of WDM Network Based On EDFA Amplifier with Different Pumping Techniques, *International Journal on Recent and Innovation Trends in Computing and Communication*, Volume: 4 Issue: 4, April 2016, ISSN: 2321-8169.
- [5] Optiwave, OptiSystem Overview, <https://optiwave.com/category/products/system-and-amplifier-design/optisystem>.