

## **Torque Profiles of Asymmetrically Wound Six-Phase Induction Motor (AWSP-IM) under Phase-Loss Conditions**

Prabhat Kumar<sup>1</sup>, K.B.Yadav<sup>2</sup>

<sup>1</sup>(Department of Electrical Engineering, NIT Jamshedpur, India)

<sup>2</sup>(Department of Electrical Engineering, NIT Jamshedpur, India)

---

**Abstract:** *A comparative analysis of torque profiles of an AWSP-IM under various phase loss conditions with respect to the healthy six-phase condition is presented. The captured plots are accompanied by a magnified (zoom) in order to obtain a better sense of the consequences on the torque-ripple content in the resulting time-domain torque profile. The phase loss scenarios analyzed in this paper are based on the simulated result of an AWSP-IM modeled using MATLAB/SIMULINK platform. The analysis of ripple contents in the torque profiles under various phase loss conditions reflects the deterioration of the torque-profile quality in each case. Further its comparison with result of three phase counterpart shows that AWSP-IM exhibits better performance than the Three Phase Induction Motor (TPIM) under the phase loss without any external control techniques. Moreover, some of the cases gave results, which were very close to the healthy operation of TPIM.*

**Keywords:** *Comparative analysis, AWSP-IM, TPIM, Torque profiles, Phase loss conditions, magnified zoom*

---

### **I. Introduction**

Very early Induction motors had two phases [1], but in all performance aspects three-phase version very soon replaced these, and resulted in a motor that was generally better. Increasing the number of phases beyond three, though may be costly, has the advantages which might be worth considering for certain special applications.

Multi-phase motors (more than three) find their application in areas which require high reliability, power density and high efficiency. Although multi-phase motor drives have been around for more than 35 years [2], it is in the last five years or so that one sees a substantial increase in the volume of research related to these motor drive systems [3]. For multiphase induction machines, as in three phase induction machines, the constant volts/hertz (V/f) control was extensively studied in the 1970's and 1980's, whereas in recent times the emphasis has shifted to vector (field-oriented) control and direct torque control of induction motors [4-8]. A most important area of research is the development of fault-tolerant control techniques for multi-phase motors [9-12]. Control algorithms used for continuous disturbance free operation of multi-phase induction and permanent magnet machines can be found in the literature in references [13, 14].

For a three-phase motor to continue operating under loss of one phase, a divided dc bus and neutral connection are required [15]. In other words, a zero sequence component is necessary to provide an undisturbed rotating MMF after a phase is lost. Due to their additional degrees of freedom, multi-phase (more than three) motors are potentially more fault tolerant than their three-phase counterparts [16]. This also eliminates the need for accessibility to the neutral line. If one phase of a multi-phase machine is open circuited, the combination of phase currents required to generate an undisturbed forward rotating MMF is no longer unique [17]. The most important consideration then is to establish an optimum set of currents which would produce the same value of MMF as under the healthy conditions.

Therefore, with proper current control, an undisturbed forward rotating MMF can be maintained, which can be used to control the electromagnetic torque.

Similar control algorithms can be worked out for any other multi-phase machine, in the case of an open-circuit. Due to additional degrees of freedom, the current in the remaining phases can be used to control the torque of the machine without the presence of negative-sequence or zero-sequence current. Some of the other areas of research include modeling of multi-phase induction machine with structural unbalance [18], influence of the loss of a stator phase /phases on the stator current spectrum. This is done through studying the behavior of some of the frequency components which depend on the speed/slip of the motor. The fluctuation of these frequencies was examined to evaluate the effect of torque ripples generated by the negative sequence component in the stator current which is associated with loss of phase/phases [19].

One of their main advantages is an inherent higher reliability at a system level and this is because, a multi-phase machine can operate with an asymmetrical winding configuration even in the case of loss of more than one inverter leg/a machine phase [20-24].

Thus, on the basis of literature survey it has been found that the conventional three-phase induction motors have an inherent drawback in so far as performance under loss of phase conditions. The two-phase operation of a three-phase induction motor doesn't provide the necessary performance such as torque and output power under applications which require high reliability such as in electric traction applications, electric ship propulsion, etc. Therefore one of the means to overcome this drawback is by the addition of more phases. The detailed investigation particularly in survivability aspects of machine under faulty conditions is quite essential from design points of view and hence the work is on improving reliability of operation of induction motors in case of phase-loss scenarios by incorporating the multi-phase (more than three) design concept.

## II. Mathematical model

A schematic representation of the stator and rotor windings for a two pole, six phase induction machine is given in fig. 1

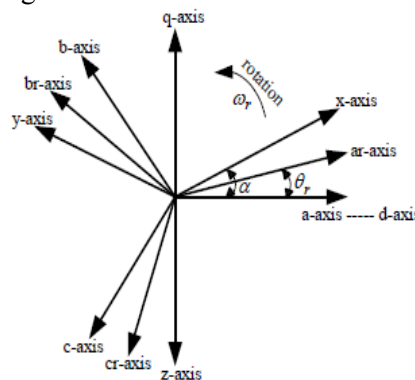

Fig.1 A two-pole six-phase induction machine with displacement between two stator winding set  
6-phase stator are divided into two Y connected three phase sets, abc and xyz, whose magnetic axes are displaced by an arbitrary angle  $\alpha$ . The windings of each 3 - phase set are uniformly distributed and have axes that are displaced 120 degree apart.

3-phase rotor windings ar, br, cr are also sinusoidal distributed and have axes that are displaced by 120 degree apart. Equations are developed, which describe the behavior of a multi-phase machine.

The following voltage equations of a multi-phase induction machine in arbitrary reference frame are:

$$v_{q1} = r_1 i_{q1} + \omega_k \lambda_{d1} + p \lambda_{q1} \quad \dots (1)$$

$$v_{d1} = r_1 i_{d1} - \omega_k \lambda_{q1} + p \lambda_{d1} \quad \dots (2)$$

$$v_{q2} = r_2 i_{q2} + \omega_k \lambda_{d2} + p \lambda_{q2} \quad \dots (3)$$

$$v_{d2} = r_2 i_{d2} - \omega_k \lambda_{q2} + p \lambda_{d2} \quad \dots (4)$$

$$0 = r_r i_{qr} + (\omega_k - \omega_r) \lambda_{dr} + p \lambda_{qr} \quad \dots (5)$$

$$0 = r_r i_{dr} - (\omega_k - \omega_r) \lambda_{qr} + p \lambda_{dr} \quad \dots (6)$$

The torque and rotor dynamics equations can be expressed as:

$$T_{em} = (3/2)(P/2)[(i_{q1} + i_{q2}) \lambda_{md} - (i_{d1} + i_{d2}) \lambda_{mq}] \quad \dots (7)$$

$i_m$  is given by

$$i_m = \sqrt{[(-i_{q1} - i_{q2} + i_{qr})^2 + (-i_{d1} - i_{d2} + i_{dr})^2]} \quad \dots (8)$$

where,

$\omega_k$  = the speed of the reference frame,

$P$  = differentiation w.r.t. time,

$\omega_r$  = the rotor speed,

and all other symbols have their usual meaning. Here, rotor quantities are referred to stator.

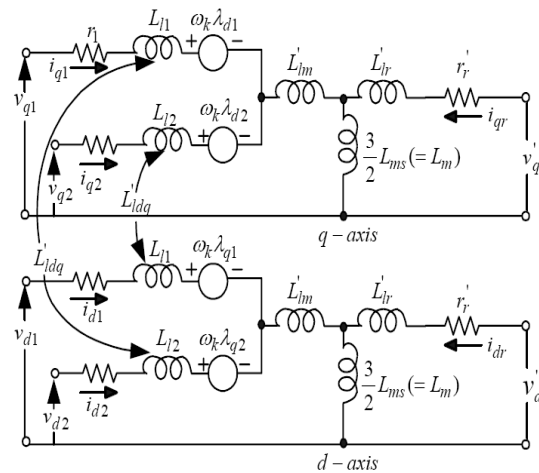

Fig. 2 The q-and d-axis equivalent circuit of a six- phase induction m/c in arbitrary reference frame

### III. Simulation of the 6-phase induction motor under various phase loss scenarios

As depicted in Fig. 3 the phase loss scenarios studied in this work are 5-phase operation where there is a loss of one phase, 4-phase operation where there is a loss of two phases and 3-phase operation where there is a loss of three phases. Furthermore, the 4-phase and 3-phase operations, in which two or three phases have been taken out of service, were studied under conditions where there is a loss of adjacent phases that is a loss of phases which are located adjacent to each other or alternately a loss of two or more phases which are non-adjacent to each other, that is the loss of phases separated by one or two other healthy phases were also studied in this work.

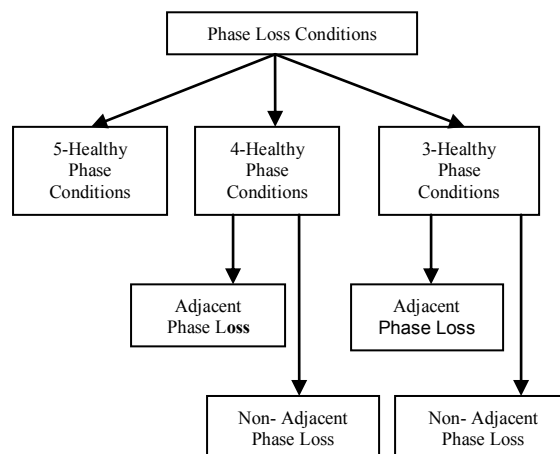

Fig.3 Flow-Chart of types of phase-loss scenarios

#### 3.1 Five-healthy phase conditions and one faulty phase operation

Here, the six-phase motor is simulated with the loss of phase A. Fig4 and Fig.5 show the phasor representation of voltages in the six-phase healthy case and the five-phase healthy and one faulty phase case, under the loss of phase A. In Fig.6 and Fig. 7 the torque profiles of the faulty case with 5 healthy phases are compared with the 6-phase healthy.

These figures are accompanied by a magnified (zoom), portion of the steady-state torque profiles, in order to obtain a better sense of the consequences of the loss of one phase on the torque-ripple content in the resulting time-domain torque profile.

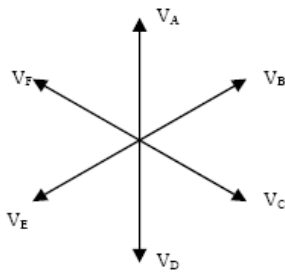

Fig. 4 Voltage phasors in healthy 6-ph operation

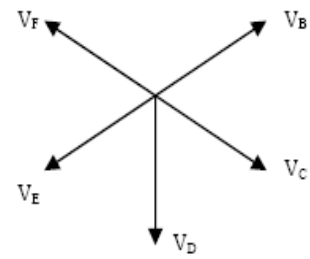

Fig. 5 Voltage phasors in the 5-ph operation with loss of phase A

From these analysis , the torque ripple content in the resulting torque is 18.33% with the 5-healthy phases and one faulty phase case, in comparison with 6.67% torque ripple content in the healthy six-phase case.

### 3.2 The four healthy phases–two faulty phase operation

Here two cases are considered, one case is the loss of two adjacent phases and the other case is the loss of two non-adjacent phases Fig.8 summarizes the four-healthy phase and two faulty phase operations.

#### 3.2.1 Loss of two adjacent phases

In this case, the six-phase motor is simulated under loss of two adjacent phases namely Phase A and Phase B. Fig.9 and Fig.10 show the phasor representation of voltages in the six-phase healthy case and the four-healthy phase faulty two-phase case under loss of phase A and phase B. In Fig. 11 and Fig. 12 phase case. These figures are accompanied by a magnified (zoom) portion of the steady-state torque profile.

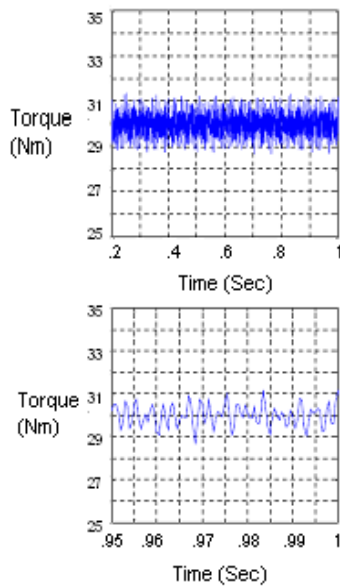

Fig. 6 Torque profile of the healthy 6-ph case under full-load

Ripple content: 6.67 %

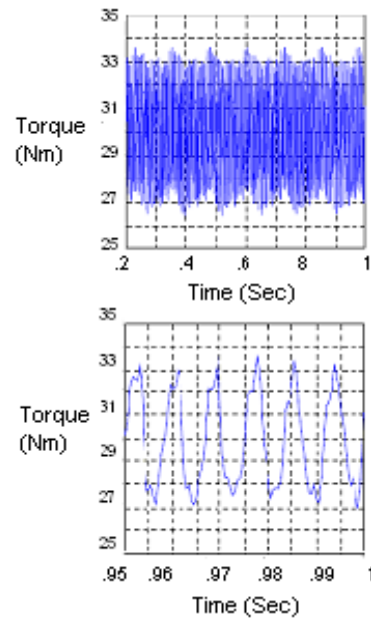

Fig. 7 Torque profile of the 5-healthy phase case with loss of phase A

Ripple content: 18.33%

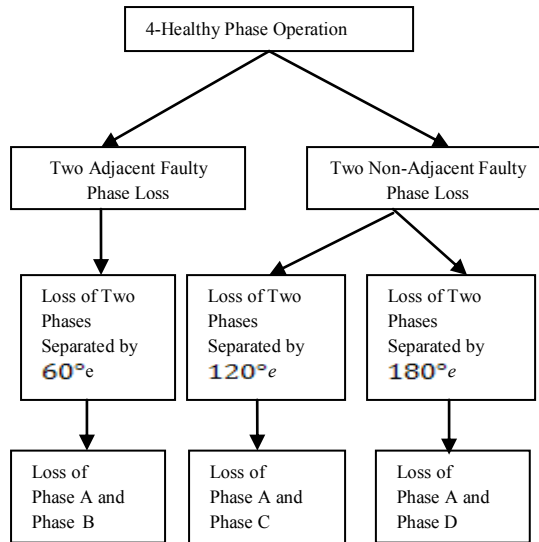

Fig. 8 Flow chart of 4-phase operations

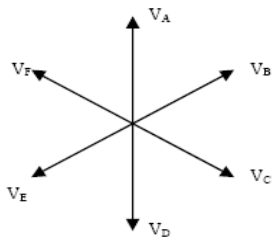

Fig.9 Voltage Phasor in healthy 6-ph operation

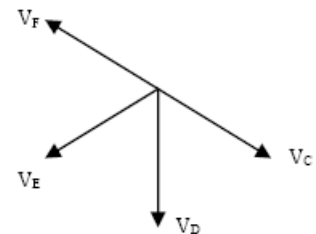

Fig.10 Voltage phasors in the four-healthy phase operation with loss of adjacent phases A and B

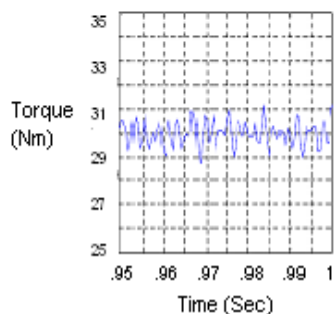
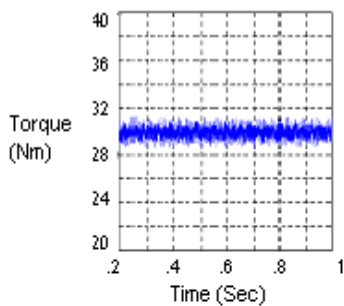

Fig.11 Torque profile of the healthy 6-phase case under full-load

Ripple content: 6.67 %

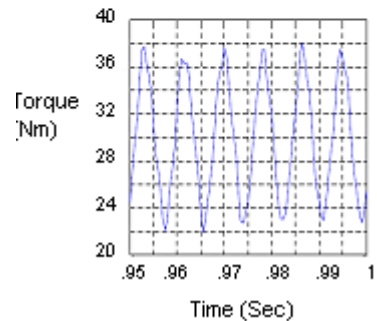
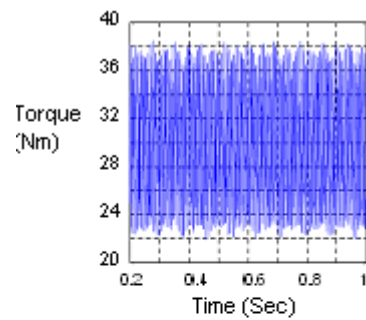

Fig.12 Torque profile of the 4-healthy phase case with loss of two adjacent phases A and B

Ripple content: 49.67 %

From the above analysis , the torque ripple content in the resulting torque is 49.67 % with the 4-healthy phases and two faulty phase adjacent to each other, in comparison with 6.67% torque ripple

content in the healthy six-phase case. This is significant, and some applications may constitute an unacceptable performance.

**3.2.2 Loss of two non-adjacent phases**

Here, the two non-adjacent faulty phase cases shown in Fig.6 are considered. In the first case, the six-phase motor is simulated under loss of two non-adjacent phases separated by  $120^\circ$  i.e., loss of phase A and phase C are considered. Fig.13 and Fig.14 show the phasor representation of the voltages in the six-phase healthy case and the four-healthy phase with faulty two-phase case such as under loss of phase A and phase C. In Fig.15 and Fig.16 the torque profile of the 4-healthy phase with two faulty phases separated by  $120^\circ$  e is compared with the 6-phase healthy case. These figures are accompanied by a magnified (zoom) portion of the steady-state torque profile.

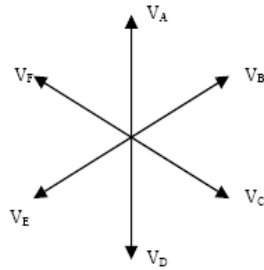

Fig.13 Voltage phasor in healthy 6-phase operation

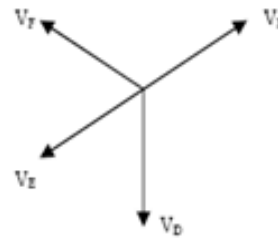

Fig.14 Voltage phasor in the four-healthy phases with two non-adjacent faulty phase with loss of phases A and C

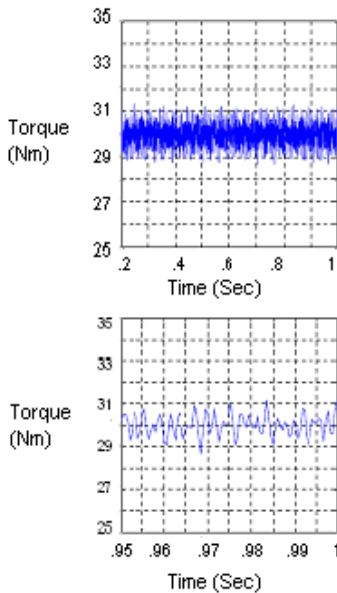

Fig. 15 Torque profile of the healthy 6-phase case under full-load

Ripple content: 6.67 %

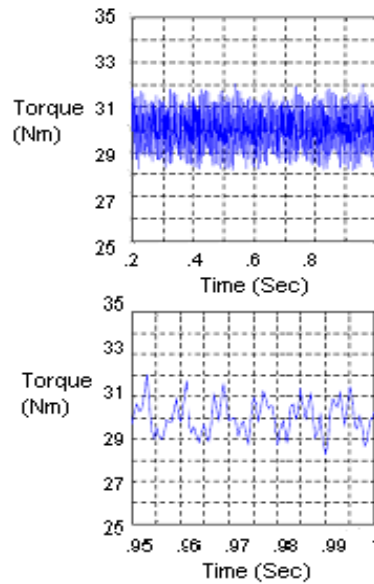

Fig. 16 Torque profile of the 4-healthy phase case with loss of two non-adjacent phases A and C

Ripple content: 10.33 %

In the second case, the six-phase motor is simulated under loss of two non-adjacent phases separated by  $180^\circ$  i.e., the loss of phase A and phase D are considered. Fig.17 and Fig.18 show the phasor representation of voltages in the six-phase healthy case and the four phase healthy case with two non-adjacent faulty phases separated by  $180^\circ$  under loss of phase A and phase D. In Fig.19 and Fig.20, the torque profile of the four-phase healthy case with two non-adjacent faulty phases separated by  $180^\circ$  e is compared with the 6-phase healthy case. Again, these figures are accompanied by a magnified (zoom) portion of the steady-state torque profile.

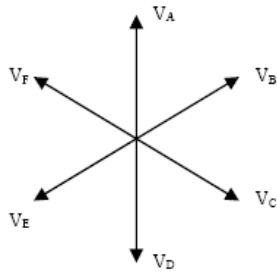

Fig.17 Voltage Phasor in healthy 6-phases operation

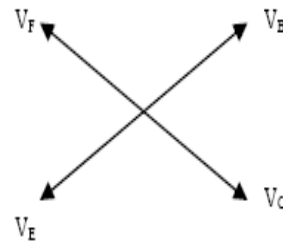

Fig.18 Voltage Phasor in the four-healthy phase with two non-adjacent faulty phase with loss of phases A and D

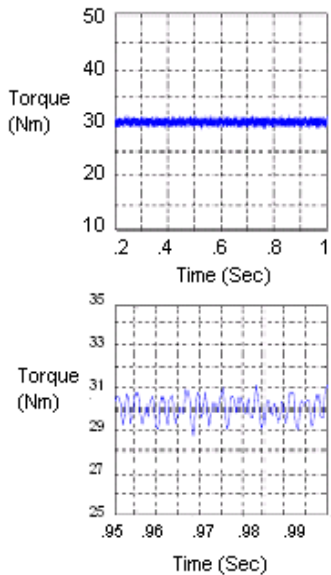

Fig.19 Torque profile of the healthy 6-phase case under full-load

Ripple content: 6.67 %

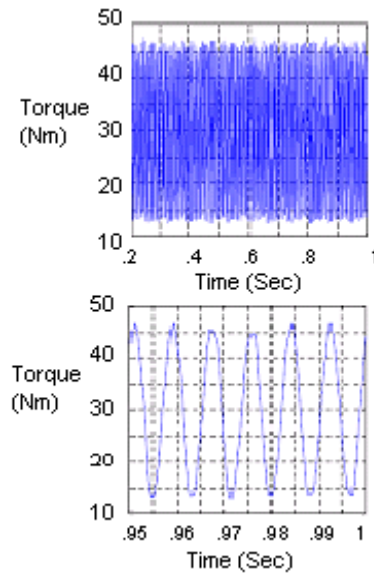

Fig.20 Torque profile of the 4-healthy phase case with loss of two non-adjacent phases A and D

Ripple content: 111%

From the above analysis, the torque ripple content in the resulting torque is 10.33 % with the 4-healthy phases and two non-adjacent faulty phase separated by  $120^\circ$ , in comparison with 6.67% torque ripple content in the healthy six-phase case whereas, the torque ripple content in the 4-healthy phases and two non-adjacent faulty phase separated by  $180^\circ$  is 111% in comparison with 6.67% torque ripple content in the healthy six-phase case. It should be observed that for the two non-adjacent faulty phase cases there is a marked difference between the  $120^\circ$  separation and the  $180^\circ$  separation cases in so far as the adverse effect on the ripple content in the time-domain torque profile. The  $120^\circ$  separation is far less severe.

### 3.3 The 3-healthy phase and 3-faulty phase operation

3.3.1 When there is loss of three adjacent phases each separated by  $60^\circ$  and when there is loss of three non-adjacent phases each separated by  $120^\circ$ . Fig. 21 summarizes the phase loss scenarios of the three-healthy phase and three faulty phase operations.

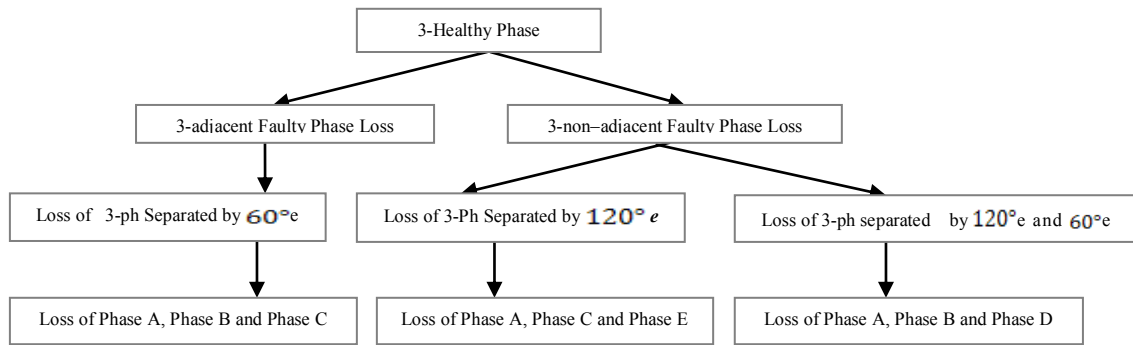

Fig.21. Flow chart summarizing the various cases of 3-phase operations.

### 3.3.1 Loss of three adjacent phases

The six-phase motor is simulated under loss of three phases adjacent to each other such as when phases A, B and C become faulty and are taken out of operation. Fig. 22 and Fig. 23 show the phasor representation of voltages in the six-phase healthy case and the three-healthy phase and three adjacent faulty phase case under loss of phases A, B and C. In Fig. 24 and Fig. 25 the torque profile of the three-healthy phase and three adjacent faulty phase case is compared with the 6-phase healthy case. These figures are accompanied by a magnified portion of the steady-state torque profile.

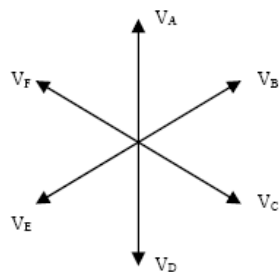

Fig. 22 Voltage Phasor in healthy 6-phases operation

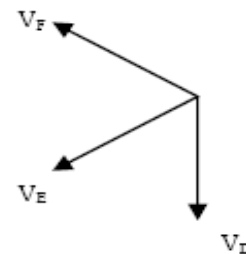

Fig.23 Voltage phasors in the 3- healthy phase operation with 3- adjacent faulty phase loss operation with loss of phases A, B and C

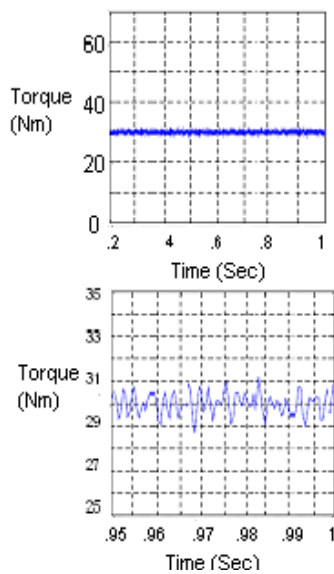

Fig. 24 Torque profile of the healthy 6-phase case under full-load

Ripple content: 6.67 %

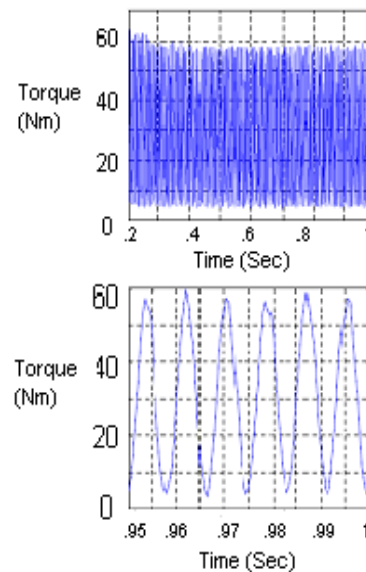

Fig. 25 Torque profile of healthy phase case with loss of three adjacent phases A, B and C

Ripple content: 178%



From the above analysis, the torque ripple content in the resulting torque is 178 % with the 3-healthy phases and three adjacent faulty phases, in comparison with 6.67% torque ripple content in the healthy six-phase case. This is a very significant amount of torque ripple and is not suitable.

**3.3.2 Loss of three non-adjacent phases**

Here, the two non-adjacent faulty phase cases shown in Fig. 26 are considered , In the first case , the six-phase motor is simulated under loss of three non-adjacent phases each separated by  $120^\circ$  , such as the loss of phase A and phase C and phase E. Fig.26 and Fig.27 show the phasor representation of the voltages in the six-phase healthy case and the three-healthy phase and three non-adjacent faulty phase separated by  $120^\circ$  case such as under loss of phase A , phase C and phase E. In Fig.28 and Fig.29 the torque profile of the 3-healthy phase with three faulty phases each separated by  $120^\circ$  is compared with the 6-phase healthy case. These figures are accompanied by a magnified (zoom) portion of the steady state torque profile.

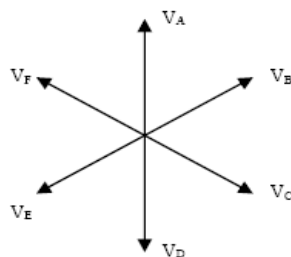

Fig. 26 Voltage Phasor in healthy 6-phases operation

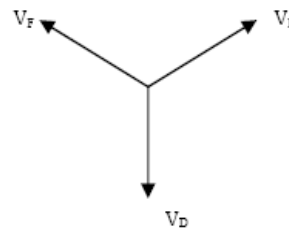

Fig. 27 Voltage phasor operation of 3-healthy phase with 3-non-adjacent phase loss operation with loss of phases A, C and E

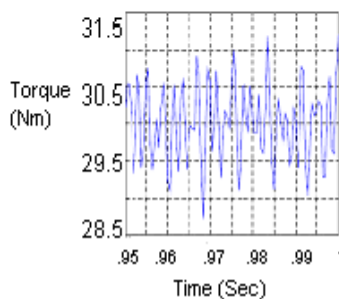
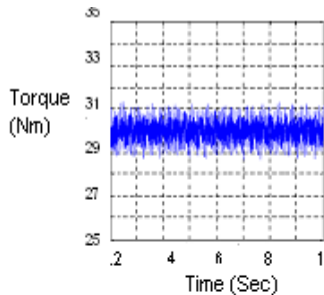

Fig. 28 Torque profile of the healthy 6-phase case under full-load

Ripple content: 6.67 %

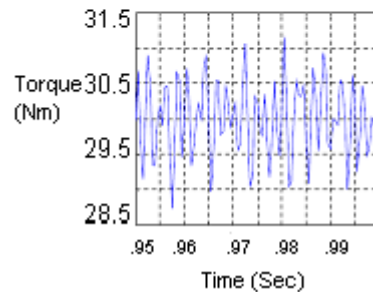
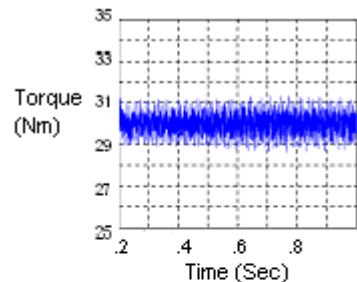

Fig. 29 Torque profile of the 3-healthy phase case with loss of three non-adjacent phases phases A, C and E

Ripple content: 7.13 %

In the second case, the six-phase motor is simulated under loss of three non-adjacent phases, two of which are separated by  $60^\circ$  and the other is separated by  $120^\circ$ , i.e. the loss of phase A, phase B and phase D are considered. Fig.30 and Fig.31 shows the phasor representation of voltages in the six-phase healthy case and the three-phase healthy case with three non-adjacent faulty phases separated by  $60^\circ$  and  $120^\circ$  under loss of phase A, phase B and phase D. In Fig.32 and Fig.33, the

torque profile of the three-phase healthy case with three non-adjacent faulty phases separated by  $60^\circ$  and  $120^\circ$  is compared with the 6-phase healthy case.

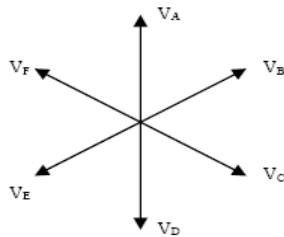

Fig.30 Voltage Phasor in healthy 6-phases operation

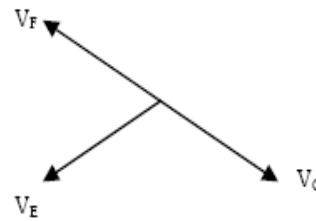

Fig. 31 Voltage phasor in the 3-healthy phases with 3-non-adjacent faulty phase loss operation with loss of phases A, B and D

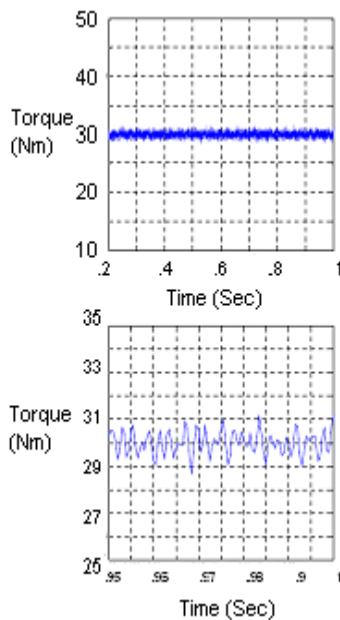

Fig.32 Torque profile of the healthy 6-phase case under full-load

Ripple content: 6.67 %

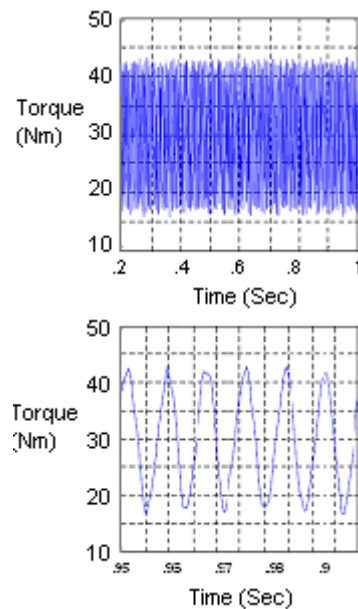

Fig. 33 Torque profile of the 3-healthy phase case with loss of three non-adjacent phases A, B and D

Ripple content: 83.6 %

From the above analysis, the torque ripple content in the resulting torque is 7.13 % with the 3-healthy phases and three non-adjacent faulty phases each separated by  $120^\circ$ , in comparison with 6.67% torque ripple content in the healthy six-phase case whereas, the torque ripple content in the 3-healthy phases and three non-adjacent faulty phase separated by  $120^\circ$  and  $60^\circ$  is 83.6 % in comparison with 6.67% torque ripple content in the healthy six-phase case. It should be observed that for the three non-adjacent faulty phase cases there is a marked difference between the  $120^\circ$  separation and the phases separated by  $120^\circ$  and  $60^\circ$  cases in so far as the adverse effect on the ripple content in the time-domain torque profile. The  $120^\circ$  separation is far less severe. It should also be observed that the ripple content in the three healthy phase and three non-adjacent faulty phase separated by  $120^\circ$  and  $60^\circ$  is far less when compared to the three phase healthy and three adjacent faulty phase operation. This would be acceptable in certain applications.

#### IV. Simulation of the two-phase healthy operation with one faulty phase in a three phase motor

Here, the case-study 5HP, 3-phase induction motor was simulated with the loss of one phase. Fig.34 and Fig.35 show the phasor representation of voltages in the 3-phase healthy case and the two-phase healthy and one-phase faulty case under the loss of phase A. In Fig.36 and Fig.37 the torque profiles of the two-phase faulty operation and the healthy 3-phase operation is compared.

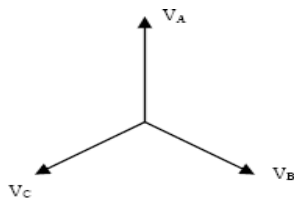

Fig.34 Voltages phasor in healthy 3- phase case

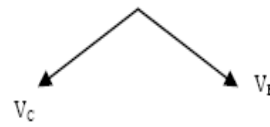

Fig. 35 Voltages phasor of the 2-healthy phase case with loss of phase A

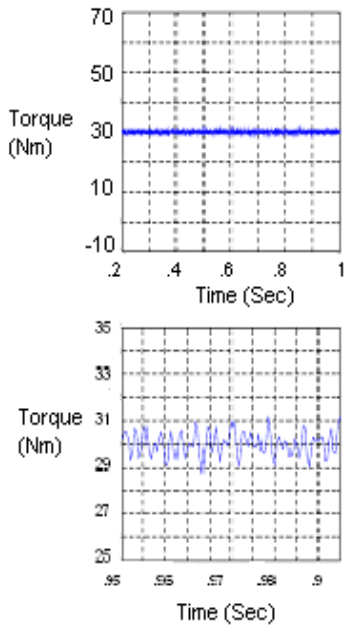

Fig. 36 Torque profile of the healthy 6-phase case under full-load

Ripple content: 6.67 %

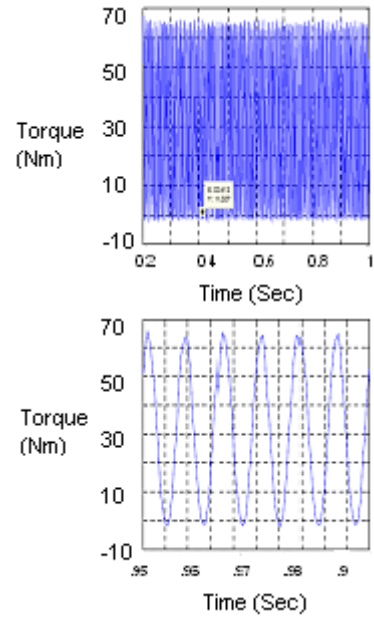

Fig. 37 Torque profile of the 2-healthy phase case with loss of phase A

Ripple content: 213%

From the above analysis, the torque ripple content in the resulting torque is 213 % with the 2-healthy phase operation, in comparison with 6.67% torque ripple content in the healthy 3-phase case. This case yields the highest and has the most adverse effect on the torque ripple content when compared to any of the cases discussed earlier.

### V. Conclusion

A comparative analysis of the various phase-loss conditions with respect to the healthy case was presented. The analysis of the ripple content in the torque under various loss of phase / phases conditions were presented. These analyses effectively reflect the deterioration of the quality of the torque-profile under the different cases. Overall, it is shown that the six-phase motor exhibits better performance under the loss of phases than the three-phase motor without any external control techniques. Moreover, some of the cases gave results which were very close to the healthy operation.

A summary representing by a table and the chart percentage torque ripple content for various faults considered in percent of the developed average torque is shown in Table.1 and Fig.38

**TABLE 1**  
Showing the torque ripple content under different phase loss cases

Case under consideration	Phases Condition	% age Torque Ripple Content
1	Healthy	6.67
2	5 Healthy Phase with loss of Phase(A)	18.33
3	4 Healthy Phase with loss of Adj phases (A,B)	49.667
4	4 Healthy Phase with loss of Non Adj phases ( A and C)	10.33
5	4 Healthy Phase with loss of Non Adj phases ( A and D)	111
6	3 Healthy Phase with loss of Adj phases ( A,B, C)	178
7	3 Healthy Phase with loss of Non Adj phases ( A,C,E )	7.13
8	3 Healthy Phase with loss of Non Adj phases ( A,B,D )	83.6
9	2-healthy phases and one faulty phase of a 3-phase motor	213

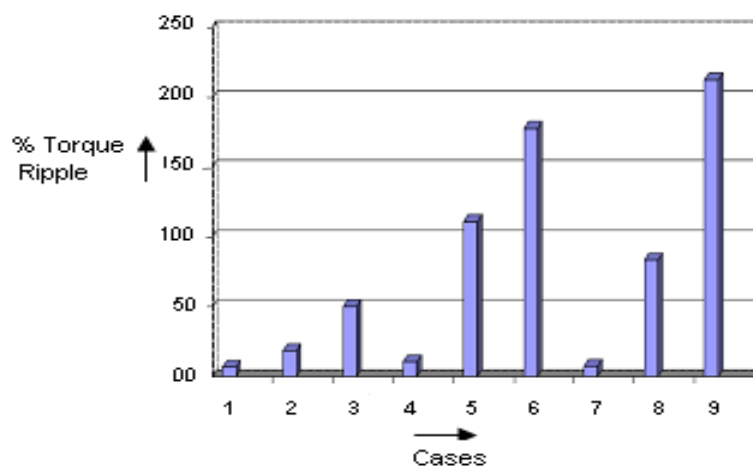

Fig. 38 Summarized chart showing the torque ripple content under different cases

Table.1 clearly indicates that the 5-healthy phase operation with one faulty phase, 3-healthy phase and three non-adjacent faulty phase operation and 4-healthy phase and two non-adjacent faulty phase operation considering loss of phases separated by  $120^\circ e$  yields the least amount of torque ripple and are almost equal in ripple content, to the healthy case. Even the 4-healthy phase non-adjacent operation considering loss of phases separated by  $180^\circ e$ , the 4- healthy phase adjacent phase-loss operation and the 3-healthy phase non-adjacent phase-loss operation exhibit relatively lower amount of torque ripple content when compared to the standard two-phase operation of a three-phase motor.

### References

- [1] T.M. Jahns. "Improved Reliability in Solid-State AC Drives by Means of Multiple Independent Phase-Drive Units." *IEEE Transactions on Industry Applications*, Vol. IA-16, pp. 321-331. May /June, 1980.
- [2] E. A. Klingshirn, "High phase order induction motors - Part I –Description and theoretical consideration," *IEEE Transactions on Power Apparatus and Systems*, vol. PAS-102, no. 1, January 1983, pp.47 -53.
- [3] G.K. Singh, "Multi-phase induction machine drive research – a survey," *Electric Power Systems Research*, vol. 61, no. 2, pp.139-147, 2002.
- [4] H. A. Toliyat and H. Xu, "DSP-based direct torque control (DTC) for five-phase induction machines," *Proc. Int. Power Electronics Conf. IPEC*, Tokyo, Japan, pp.1195-1200, 2000.
- [5] E. Levi, S.N. Vukosavic and M. Jones, "Vector control schemes for series-connected six-phase two-motor drive systems," *IEE Proc. – Electric Power Applications*, vol. 152, no. 2, pp. 226-238, 2005.
- [6] R. Bojoi, F. Farina, G. Griva, F. Profumo and A. Tenconi, "Direct torque control for dual three-phase induction motor drives," *IEEE Trans. on Industry Applications*, vol. 41, no. 6, pp.1627-1636, 2005.
- [7] Peter Vas, *Sensorless Vector and Direct Torque Control*, Oxford University Press, 1998.
- [8] B. K. Bose, *Power Electronics and AC Drives*, Prentice-Hall, Englewood Cliffs, New Jersey, 1986.
- [9] J.B. Wang, K. Atallah and D. Howe, "Optimal torque control of fault-tolerant permanentmagnet brushless machines," *IEEE Trans. on Magnetics*, vol. 39, no. 5, pp. 2962-2964, 2003.
- [10] B.C. Mecrow, A. G. Jack, D.J. Atkinson, S.R. Green, G.J. Atkinson, A. King and B. Green, "Design and testing of a Four phase fault-tolerant permanent magnet machine for an engine fuel pump," *IEEE Trans. on Energy Conversion*, vol.19, no. 3, pp. 671-678, 2004.

- [11] G.J. Atkinson, B.C. Mecrow, A.G. Jack, D.J. Atkinson, P. Sangha and M. Benarous, "The design of fault tolerant machines for aerospace applications," *Proc. IEEE Int. Electric Machines and Drives Conf. IEMDC*, San Antonio, TX, pp.1863-1869, 2005.
- [12] A.J. Mitcham, G. Antonopoulos and J.J.A. Cullen, "Favourable slot and pole number combinations for fault-tolerant PM machines," *IEE Proc. - Electrical Power Applications*, vol.151, no. 5, pp. 520-525, 2004.
- [13] J. R. Fu and T.A. Lipo, "Disturbance free operation of a multiphase current regulated motor drive with an open phase", *IEEE Trans on Ind Applications*, Vol. 30, Issue.5, Sep. – Oct. 1994, pp.1267 -1274.
- [14] Leila Parsa, Hamid A. Toliyat, "Fault-Tolerant Interior-Permanent-magnet Machines for Hybrid Electric Vehicle Applications", *IEEE Transactions on Vehicular Technology*, Vol.56, No.4, July 2007, pp, 1546-1552.
- [15] T. H. Liu, J. R. Fu, and T. A. Lipo, "A strategy for improving reliability of field oriented controlled induction motor drives," 1991 *IEEE U S Annu. Meet. Conf. Rec.*, vol. 1, pp. 449-455, 1991.
- [16] C. B. Jacobina, R. S. Miranda, M. B. de R. Corrêa, A. M. N. Lima, "Disturbance-Free operation of a six-phase AC motor drive system", *IEEE Power Electronics Specialist Conference*, Aachen Germany, 2004.
- [17] H. A. Toliyat, "Analysis and simulation of multi-phase variable speed induction motor drives under asymmetrical connections", *APEC '96*, Volume 2, 3-7 March 1996, pp.586 -592.
- [18] Yifan Zhao, Thomas A. Lipo, "Modeling and control of a multi-phase induction machine with structural unbalance", *IEEE Transactions on Energy Conversion*, vol.11, No.3, September 1996, pp.578-584.
- [19] Gerard Aroquiadassou, Humberto Henao, "Experimental Analysis of the dqo stator current component spectra of a 42V fault-tolerant six-phase induction machine drive with opened stator phases", *Diagnostics for Electric Machines, Power Electronics and Drives*, 2007. September 2007, pp. 52-57.
- [20] J. P. Martin and F. Meibody-Tabar, "Multi - phase permanent magnet synchronous machine supplied by VSIs, working under fault conditions", *IEEE Industry Applications Conference*, Volume 3, 8-12 Oct. 2000, pp.1710-1717.
- [21] N.A.O. Demerdash, "Design and Analysis of Electric Motors in Adjustable Speed Drives" Class Notes for EECE 185, Department of Electrical and Computer Engineering, Marquette University, Milwaukee, Wisconsin, Fall 2007.
- [22] Miranda R. S., Jacobina C. B., Lima A. M. N. "Modeling and analysis of six-phase induction machine under fault condition", *Power Electronics Conference*. P. 824-830, 2009.
- [23] M. A. Fnaiech, F. Betin, G. A. Capolino, and F. Fnaiech, "Fuzzy Logic and Sliding-Mode Controls Applied to Six-Phase Induction Machine With Open Phase," *IEEE Trans on Industrial Electronics*, vol. 57, no. 1, pp. 354-364, Jan 2010.
- [24] B. Kundrotas, S. Lisauskas, R. Rinkeviciene. "Model of Multiphase Induction Motor / Electronics and electrical Engineering" – *Kaunas: Technologija*, – No. 5(111). – P. 111-114. 2011.